

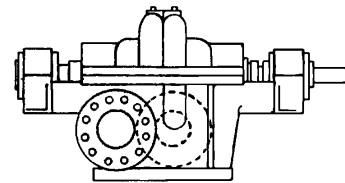

## PRODUCT BULLETIN MODEL HK MULTISTAGE



Three factors were given top consideration when the American-Marsh Model HK pump was developed by our engineers. Important operating features combine to give you economical initial cost and installation, plus high, lasting efficiency, with the resultant low operating cost and low maintenance expense because of simplicity of design and ease of replacement parts when necessary – factors that every operating engineer considers most important.

### Material Specifications

PART	CONSTRUCTION			
	BRONZE FITTED	ALL IRON	NI-RESIST FITTED	316SS FITTED
Casing	Cast Iron	Cast Iron	Cast Iron	Cast Iron
Impellers	Bronze	Cast Iron	Ni-Resist	316 Stainless Steel
Shaft	420 Stainless Steel	420 Stainless Steel	Stainless	316 Stainless Steel
Lantern Rings	Bronze	Cast Iron	Ni-Resist	316 Stainless Steel
Stuffing Box Glands	Bronze	Cast Iron	Ni-Resist	316 Stainless Steel
Shaft Sleeves	Bronze	416 Stainless Steel	316 Stainless Steel	316 Stainless Steel
Bearing Housings	Cast Iron	Cast Iron	Cast Iron	Cast Iron
Mechanical Seal	Carbon/Si-C/Buna	Carbon/Si-C/Buna	Carbon/Si-C/Buna	Carbon/Si-C/Buna

### MODEL HK SPECIFICATIONS

**Casing:** The casing is of cast iron, or other specified material, of the volute type with external water passages and split on the horizontal centerline with suction and discharge nozzles, cast integral with the lower half. Removal of the upper half of the casing gives complete access to the interior of the pump without disturbing pipe connections or alignment. Ample wall thickness provides a generous allowance for corrosion. The stage arrangement is such that one stuffing box is under suction pressure only with the other box subject only to first stage pressure. Furthermore, the maximum pressure difference across any of the stage pieces, separating the impeller chambers, is reduced to that of the first stage. Impellers are opposed or back-to-back to eliminate end thrust and volutes are staggered to balance radial thrust. This hydraulic balancing of all radial or end thrust is obtained without the use of troublesome balancing disks or other devices that reduce efficiency. Thus the efficiency of the HK is inherently high and sustained over long periods of time.

**Impellers:** The impellers are of bronze or other specified alloy. They are the single suction, enclosed type, with the outer surfaces machined and polished with hand finished water passages. Hydraulic balancing is accomplished as described in the above paragraph and impellers are mechanically balanced after machining.

**Casing and Impeller Wear Rings:** The case and impeller wear rings are of bronze or other specified material. Both rings have large wearing surfaces to reduce leakage losses. Casing wearing rings are held rigidly in the casing by a tongue and groove fit with offset on the horizontal centerline – thus preventing rotation without using holding pins or screws.

**Shaft:** The shaft is of 420 stainless steel, or other specified material, ground finished to close tolerances and of ample proportions to safely transmit the maximum power as well as avoiding all critical speeds in

operation. Impeller keys are staggered to prevent uneven stresses and unbalance.

**Shaft Sleeves:** The shaft sleeves are of bronze, or other specified material, extending from the impeller hub through the stuffing boxes and secured to the shaft by impeller key extension. Longitudinal position is maintained by twin locknuts. Stuffing boxes prevent leakage along the shaft while allowing freedom for the sleeve to expand independently of the shaft expansion.

**Stuffing Boxes:** are arranged for water cooling and are extra deep. Throat bushings protect main casing from wear. Lantern rings are provided with in-and-out connections provided for both boxes to permit the circulation of sealing water, or a lubricating medium when required by special service conditions. Stuffing boxes are of the split type for ease in removal when repacking. A wide variety of mechanical seals are available upon request.

**Bearing Housings:** Bearings housings are split on the horizontal centerline, similar to the pump casing, so that the housings need not be detached from the lower part of the casing when removing the rotating element. The bearings are of the double row type with positive ring-oil lubrication. The inboard bearing carries the radial load and is free to move in either direction. The outboard bearing is of the angular contact, duplex type to carry either radial or unbalanced thrust loads and maintain impellers in their proper positions. The cooling water jacket extends around the entire circumference of the bearing housing so that cooling is uniform and no damaging stresses are set up as might be the case when the cooling jacket is only around one-half the circumference as used in older designs. No gaskets are required, so cooling water cannot leak into oil reservoirs and bearing replacements will always fit.

**INDUSTRIAL**  
Process, Petrochemical,  
Chemical Injection

**COMMERCIAL**  
HVAC, Booster, Boiler Feed,  
High Rise, Condenser Water

**MUNICIPAL**  
Booster Systems, Chemical Injection

**PRODUCT BULLETIN**  
**MODEL HK MULTISTAGE**

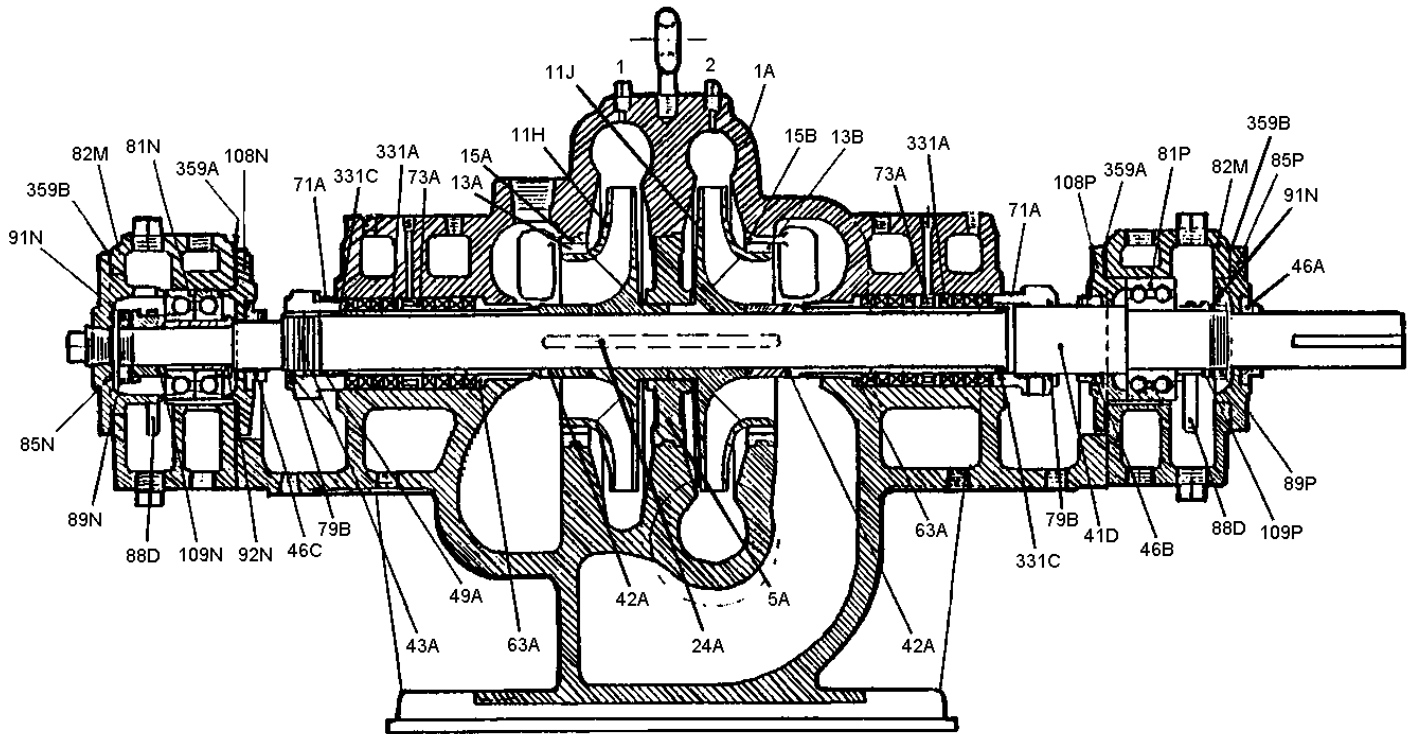

HK Sectional Drawing

Item Number	Item Description	Num. Req.
1A	Casing	1
5A	Stage Piece	1
11H	Impeller, First Stage	1
11J	Impeller, Second Stage	1
13A	Ring, Impeller Wearing, First Stage	1
13B	Ring, Impeller Wearing, Second Stage	1
15A	Ring, Casing Wearing	1
15B	Ring, Casing Wearing	1
24A	Key, Impeller, First Stage	1
41D	Shaft	1
42A	Sleeve, Shaft	2
43A	Nut, Shaft Sleeve Lock	2
46A	Slinger, Shaft Fluid, Inbd/Outbd	1
46B	Slinger, Shaft Fluid, Inbd/Inbd	1
46C	Slinger, Shaft Fluid, Outbd/Inbd	1
47A*	Set Screw, Shaft Slinger	6
49A	Gland, Shaft Sleeve	1
63A	Bushing, Stuffing Box Throat	2
71A	Gland, Stuffing Box	2
72C*	Bolt, Gland Hinge	4
73A	Ring, Lantern	2
79B	Gasket, Stuffing Box Gland	2

Item Number	Item Description	Num. Req.
81N	Bearing, Outboard Ball, Thrust	2
81P	Bearing, Inboard Ball, Radial	1
82M	Housing, Bearing	2
85N	Cap, Outboard Bearing	1
85P	Cap, Inboard Bearing	1
88D	Ring, Bearing Oil	2
89N	Locknut, Outboard Bearing	1
89P	Locknut, Inboard Bearing	1
91P	Lockwasher, Inboard Bearing	2
92N	Adapter, Outboard Bearing	1
108N	Cap, Bearing Manifold, Outboard	1
108P	Cap, Bearing Manifold, Inboard	1
109N	Collar, Oil Ring, Outboard	1
109P	Collar, Oil Ring, Inboard	1
181A*	Pipe, Fluid Seal Connecting	1 set
282B*	Oiler, Constant Level	2
331A	Packing, Stuffing Box	1 set
331C	O-Ring, Shaft Sleeve	4
353A*	Gasket, Casing	1
359A	Gasket, Bearing Housing, Rubber	2
359B	Gasket, Bearing Housing, Manilla	2
381F*	Nuts, Cap for Casing Studs	Varies

\* Not shown in sectional.

Recommended spare parts are in **BOLD**.