

INSTALLATION, OPERATION &  
MAINTENANCE MANUAL  
FOR  
SERIES 460  
OSG ANSI PROCESS END  
SUCTION PUMP

26 January 2011  
Copyright © 2011 American-Marsh Pumps

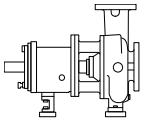

# CONTENTS

Page #

DANGER ..... 4  
 WARNING ..... 4  
 CAUTION..... 4

**PUMP IDENTIFICATION ..... 5**

MANUFACTURER ..... 5  
 TYPE OF PUMP ..... 5  
 DATE OF MANUFACTURE ..... 5  
 INSTALLATION, OPERATION & MAINTENANCE MANUAL IDENTIFICATION ..... 5  
 NAMEPLATE INFORMATION..... 5

**SAFETY CONSIDERATIONS ..... 6**

**WARRANTY ..... 6**

**GENERAL INSTRUCTIONS..... 6**

**HANDLING AND TRANSPORT ..... 6**

METHOD OF TRANSPORT ..... 6  
 INSTALLATION ..... 6

**STORAGE..... 7**

SHORT-TERM STORAGE ..... 7  
 LONG-TERM STORAGE..... 7

**INSTALLATION & ALIGNMENT ..... 7**

FACTORY PRELIMINARY ALIGNMENT PROCEDURE..... 7  
 RECOMMENDED PROCEDURE FOR BASE PLATE INSTALLATION & FINAL FIELD ALIGNMENT ..... 8  
   NEW GROUTED BASE PLATES ..... 8  
   EXISTING GROUTED BASE PLATES..... 9  
 PIPING CONNECTION – SUCTION & DISCHARGE ..... 10  
   SUCTION PIPING..... 10  
   DISCHARGE PIPING ..... 11  
 PUMP AND SHAFT ALIGNMENT CHECK..... 11  
 MECHANICAL SEAL ..... 11  
 PACKING..... 11  
 PIPING CONNECTION –SEAL/PACKING SUPPORT SYSTEM ..... 11  
 COUPLING ..... 13

**PUMP OPERATION ..... 13**

ROTATION CHECK..... 13  
 PRE START-UP CHECKS..... 13  
 ENSURING PROPER NPSH<sub>A</sub> ..... 13  
 MINIMUM FLOW ..... 13  
 STARTING THE PUMP AND ADJUSTING FLOW ..... 14  
 OPERATION IN SUB-FREEZING CONDITIONS..... 15  
 SHUTDOWN CONSIDERATIONS ..... 15  
 TROUBLESHOOTING ..... 15

**MAINTENANCE..... 20**

PREVENTIVE MAINTENANCE ..... 20  
 NEED FOR MAINTENANCE RECORDS ..... 20  
 MAINTENANCE SCHEDULE ..... 20  
 NEED FOR CLEANLINESS..... 20

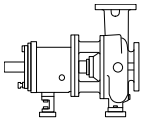

DISASSEMBLY ..... 20

CLEANING/INSPECTION ..... 22

CRITICAL MEASUREMENT AND TOLERANCES ..... 22

ASSEMBLY ..... 23

POWER END ASSEMBLY ..... 23

**BEARING INSTALLATION** ..... 23

**ALL MODELS** ..... 26

**BEARING LUBRICATION** ..... 29

**SPARE PARTS** ..... **30**

    RECOMMENDED SPARE PARTS – STANDARD OSG PUMP ..... 30

    HOW TO ORDER SPARE PARTS ..... 30

**APPENDIX A** ..... **35**

    CRITICAL MEASUREMENTS AND TOLERANCES FOR MAXIMIZING MTBPM ..... 35

        PARAMETERS THAT SHOULD BE CHECKED BY USERS ..... 35

        ADDITIONAL PARAMETERS CHECKS BY AMERICAN-MARSH ..... 35

        SHAFT ..... 36

        IMPELLER BALANCING ..... 36

        BEARING HOUSING ..... 36

        POWER FRAME ASSEMBLY ..... 36

        SEAL CHAMBER ..... 37

        COMPLETE PUMP ..... 37

    SPECIAL PARAMETERS CHECKED BY AMERICAN-MASH ..... 38

        SHAFT – MAXIMUM ROUGHNESS AT SEAL CHAMBER ..... 38

        BEARING HOUSING – BORE CONCENTRICITY ..... 38

        COMPLETE PUMP – DYNAMIC SHAFT DEFLECTION ..... 38

**APPENDIX B** ..... **39**

    IMPELLER CLEARANCE SETTING ..... 39

    AMERICAN-MARSH OSG MAINTENANCE INSTRUCTIONS BEARING HOUSING OIL SEALS (LABYRINTH TYPE)

    INPRO/SEAL® VBXX BEARING ISOLATORS ..... 40

**APPENDIX D** ..... **42**

    ALLOWABLE NOZZLE LOADS OSG PUMPS (ASME B73.1M) ..... 42

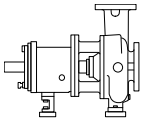

### SAFETY CONSIDERATIONS

The American-Marsh OSG process pump has been designed and manufactured for safe operation. In order to ensure safe operation, it is very important that this manual be read in its entirety prior to installing or operating the pump. American-Marsh Pumps shall not be liable for physical injury, damage or delays caused by a failure to observe the instructions for installation, operation and maintenance contained in this manual.

Remember that every pump has the potential to be dangerous, because of the following factors:

- parts are rotating at high speeds
- high pressures may be present
- high temperatures may be present
- highly corrosive and/or toxic chemicals may be present

Paying constant attention to safety is always extremely important. However, there are often situations that require special attention. These situations are indicated throughout this book by the following symbols:



**DANGER** - Immediate hazards which WILL result in severe personal injury or death.



**WARNING** – Hazards or unsafe practices which COULD result in severe personal injury or death.



**CAUTION** – Hazards or unsafe practices which COULD result in minor personal injury or product or property damage.

Maximum Lifting Speed: 15 feet/second.

If in a climate where the fluid in the casing could freeze, never leave liquid in the pump casing. Drain the casing completely. During winter months and cold weather, the liquid could freeze and damage the pump casing.

Do not run the equipment dry or start the pump without the proper prime (casing flooded).

Do not exceed the Maximum Design Pressure (MDP) at the temperature shown on the nameplate. See figure 2, page 8 for general pressure versus temperature ratings of common alloys.

Never operate the pump for more than a short interval with the discharge valve closed. The length of the interval depends on several factors including the nature of the fluid pumped and its temperature. Contact American-Marsh Engineering for additional support if required.

Never operate the pump with a closed suction valve.

Excessive pump noise or vibration may indicate a dangerous operating condition. The pump must be shutdown immediately.

Do not operate the pump for an extended period of time below the recommended minimum flow.

The pump shaft MUST turn clockwise when viewed from the motor end. It is absolutely essential that the rotation of the motor be checked before installation of the coupling spacer and starting the pump. Incorrect rotation of the pump for even a short period of time can unscrew the impeller, which can cause severe damage.

If the liquid is hazardous, take all necessary precautions to avoid damage and injury before emptying the pump casing.

Residual liquid may be found in the pump casing, head and suction line. Take the necessary precautions if the liquid is hazardous, flammable, corrosive, poisonous, infected, etc.

Always lockout power to the driver before performing pump maintenance.

Never operate the pump without the coupling guard and all other safety devices correctly installed.

Do not apply heat to disassemble the pump or to remove the impeller. Entrapped liquid could cause an explosion.

If any external leaks are found while pumping hazardous product, immediately stop operations and repair.

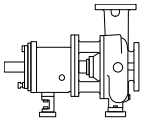

## PUMP IDENTIFICATION

### MANUFACTURER

American-Marsh Pumps  
185 Progress Road  
Collierville, TN 38017  
United States of America

### TYPE OF PUMP

The American-Marsh OSG chemical process pump is a horizontal, end suction, single stage, centerline

discharge, centrifugal pump. It is an "ANSI" standard pump, which means it conforms to the ASME B73.1M ANSI standard.

### DATE OF MANUFACTURE

The date of manufacture is indicated on the pump data plate.

### INSTALLATION, OPERATION & MAINTENANCE MANUAL IDENTIFICATION

Prepared: January, 2011  
Revision:

Edition: 01  
Date of Revision:

## NAMEPLATE INFORMATION

AMERICAN-MARSH PUMPS			
EQUIP NO.			
SIZE			
ALLOY	BASE		
SEAL	TYPE		
SEAL CODE			
CAPACITY	TDH		
RPM	MDP		
TEMP	SG	V	
SERIAL NO.	CE		

FIGURE 1 – Pump Data Plate

- EQUIP NO. : Tag information supplied by end user.
- SIZE : Size designation of pump (3x4-10 OSG)
- ALLOY : Construction of pump. Casing Material / Impeller Material (DS/DS).
- BASE : ANSI base designation.
- SEAL : Seal manufacturer (AMP, JC, etc).
- TYPE : Seal type (810, 820, 1, 21, 442, etc.).
- SEAL CODE : Material construction of seal (C20/E1 - X74/E1 - S316 - S316).
- CAPACITY : Rated capacity of pump.
- TDH : Rated Total Dynamic Head of pump.
- RPM : Speed of pump.
- MDP : Maximum design pressure of pump at 100 degrees Fahrenheit.
- TEMP : Temperature of pumped fluid.
- SG : Specific Gravity of pumped fluid.
- V : Viscosity of pumped fluid.
- SERIAL NUMBER : Serial Number of pump unit (issued by Production Control).
- CE : Location where built.

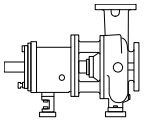

## SAFETY CONSIDERATIONS

Material	-350°F to 100°F	101°F to 200°F	200°F to 300°F	300°F to 400°F	401°F to 500°F
Ductile Iron	280 psig	260 psig	225 psig	200 psig	175 psig
316 SS	275 psig	230 psig	210 psig	185 psig	175 psig
Alloy 20	225 psig	210 psig	195 psig	180 psig	175 psig
Hastelloy C	285 psig	260 psig	225 psig	200 psig	175 psig

-40°F Minimum Temperature for Ductile Iron

**FIGURE 2 – Maximum Working Pressure Limits: Class 150 Flanges**

Material	-310°F to 100°F	101°F to 200°F	200°F to 300°F	300°F to 400°F	401°F to 500°F
Ductile Iron	370 psig	340 psig	310 psig	280 psig	260 psig
316 SS	370 psig	340 psig	310 psig	280 psig	260 psig
Alloy 20	370 psig	340 psig	310 psig	280 psig	260 psig
Hastelloy C	370 psig	340 psig	310 psig	280 psig	260 psig

-40°F Minimum Temperature for Ductile Iron

**FIGURE 3 – Maximum Working Pressure Limits: Class 300 Flanges**

## WARRANTY

American-Marsh Pumps guarantees that only high quality materials are used in the construction of our pumps and that machining and assembly are carried out to high standards.

The pumps are guaranteed against defective materials and/or faulty craftsmanship for a period of one year from the date of shipment unless specifically stated otherwise.

Replacement of parts or of the pump itself can only be carried out after careful examination of the pump by qualified personnel.

**The warranty is not valid if third parties have tampered with the pump.**

This warranty does not cover parts subject to deterioration or wear and tear (mechanical seals, pressure and vacuum gauges, rubber or plastic items, bearings, etc.) or damage caused by misuse or improper handling of the pump by the end user.

Parts replaced under warranty become the property of American-Marsh Pumps.  
Contact the American-Marsh Pumps' factory:

**American-Marsh Pumps**  
185 Progress Road  
Collierville, TN 38017  
United States Of America

**Phone: (901) 860-2300**  
**Fax: (901) 860-2323**  
**www.american-marsh.com**

## GENERAL INSTRUCTIONS

The pump and motor unit must be examined upon arrival to ascertain any damage caused during shipment. If damaged immediately notify the carrier and/or the sender. Check that the goods correspond exactly to the description on the shipping documents and report any differences as soon as possible to the sender. Always quote the pump type and serial number stamped on the data plate.

**The pumps must be used only for applications for which the manufacturers have specified:**

- ❖ The construction materials
- ❖ The operating conditions (flow, pressure, temperature, etc.)
- ❖ The field of application

In case of doubt, contact the manufacturer.

## HANDLING AND TRANSPORT

### METHOD OF TRANSPORT

The pump must be transported in the horizontal position

### INSTALLATION

During installation and maintenance, all components must be handled and transported securely by using suitable slings. Handling must be carried out by specialized personnel to avoid damage to the pump and persons. The lifting rings attached to various components should be used exclusively to lift the components for which they have been supplied.

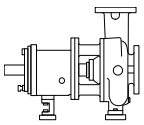

# CAUTION

**Maximum lifting speed: 15 feet/second**

## STORAGE

### SHORT-TERM STORAGE

Normal packaging is designed to protect the pump during shipment and for dry, indoor storage for up to two months or less. The procedure followed for this short-term storage is summarized below:

Standard Protection for Shipment :

- a. Loose unmounted items, including, but not limited to, oilers, packing, coupling spacers, stilts, and mechanical seals are packaged in a water proof plastic bag and placed under the coupling guard. Larger items are cartoned and metal banded to the base plate. For pumps not mounted on a base plate, the bag and/or carton is placed inside the shipping carton. All parts bags and cartons are identified with the American-Marsh sales order number, the customer purchase order number, and the pump item number (if applicable).
- b. Inner surfaces of the bearing housing, shaft (area through bearing housing), and bearings are coated with Cortec VCI-329 rust inhibitor, or equal.  
**Note: Bearing housings are not filled with oil prior to shipment.**
- c. Regreasable bearings are packed with grease (Royal Purple NLGI#2).
- d. After a performance test, if required, the pump is tipped on the suction flange for drainage (some residual water may remain in the casing). Then, internal surfaces of ferrous casings, covers, flange faces, and the impeller surface are sprayed with Calgon Vestal Labs RP-743m, or equal. Exposed shafts are taped with Polywrap.
- e. Flange faces are protected with plastic covers secured with plastic drive bolts. 3/16 in (7.8 mm) steel or 1/4 in (6.3 mm) wood covers with rubber gaskets, steel bolts, and nuts are available at extra cost.
- f. All assemblies are bolted to a wood skid which confines the assembly within the perimeter of the skid.
- g. Assemblies with special paint are protected with a plastic wrap.
- h. Pumps, when not mounted on base plates, are packed in hard paper cartons mounted on wood skids.

- i. All pump assemblies utilizing polycrete base plates are mounted on wood skids.
- j. All assemblies having external piping (seal flush and cooling water plans), etc. are packaged and braced to withstand normal handling during shipment. In some cases components may be disassembled for shipment. The pump must be stored in a covered, dry location.

### LONG-TERM STORAGE

Long-term storage is defined as more than two months, but less than 12 months. The procedure American-Marsh follows for long-term storage of pumps is given below. These procedures are in addition to the short-term procedure.

Solid wood skids are utilized. Holes are drilled in the skid to accommodate the anchor bolt holes in the base plate, or the casing and bearing housing feet holes on assemblies less base plate. Tackwrap sheeting is then placed on top of the skid and the pump assembly is placed on top of the Tackwrap. Metal bolts with washers and rubber bushings are inserted through the skid, the Tackwrap, and the assembly from the bottom of the skid and are then secured with hex nuts. When the nuts are "snugged" down to the top of the base plate or casing and bearing housing feet, the rubber bushing is expanded, sealing the hole from the atmosphere. Desiccant bags are placed on the Tackwrap. The Tackwrap is drawn up around the assembly and hermetically (heat) sealed across the top. The assembly is completely sealed from the atmosphere and the desiccant will absorb any entrapped moisture. A solid wood box is then used to cover the assembly to provide protection from the elements and handling. This packaging will provide protection up to twelve months without damage to mechanical seals, bearings, lip seals, etc. due to humidity, salt laden air, dust, etc. After unpacking, protection will be the responsibility of the user. Addition of oil to the bearing housing will remove the inhibitor. If units are to be idle for extended periods after addition of lubricants, inhibitor oils and greases should be used.

**Every three months, the shaft should be rotated approximately 10 revolutions.**

## INSTALLATION & ALIGNMENT

### FACTORY PRELIMINARY ALIGNMENT PROCEDURE

The purpose of factory alignment is to ensure that the user will have full utilization of the clearance in the motor holes for final job-site alignment. To achieve this, the factory alignment procedure specifies that the pump be

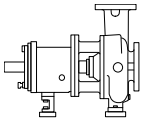

aligned in the horizontal plane to the motor, with the motor foot bolts centered in the motor holes. This procedure ensures that there is sufficient clearance in the motor holes for the customer to field align the motor to the pump, to zero tolerance. This philosophy requires that the customer be able to place the base in the same condition as the factory. Thus the factory alignment will be done with the base sitting in an unrestrained condition on a flat and level surface. This standard also emphasizes the need to ensure the shaft spacing is adequate to accept the specified coupling spacer. The factory alignment procedure is summarized below:

1. The base plate is placed on a flat and level work bench in a free and unstressed position.
2. The base plate is leveled as necessary. Leveling is accomplished by placing shims under the rails (or, feet) of the base at the appropriate anchor bolt hole locations. Levelness is checked in both the longitudinal and lateral directions.
3. The motor and appropriate motor mounting hardware is placed on the base plate and the motor is checked for any planar soft-foot condition. If any is present it is eliminated by shimming.
4. The motor feet holes are centered around the motor mounting fasteners.
5. The motor is fastened in place by tightening the nuts on two diagonal motor mounting studs.
6. The pump is put onto the base plate and leveled. The foot piece under the bearing housing is adjustable. It is used to level the pump, if necessary. If an adjustment is necessary, we add or delete shims (#109A) between the foot piece and the bearing housing.
7. The spacer coupling gap is verified.
8. The parallel and angular *vertical* alignment is made by shimming under the motor.
9. All four motor feet are tightened down.
10. The pump and motor shafts are then aligned *horizontally*, both parallel and angular, by *moving the pump* to the fixed motor. The pump feet are tightened down.
11. Both horizontal and vertical alignment are again final checked as is the coupling spacer gap.

## **RECOMMENDED PROCEDURE FOR BASE PLATE INSTALLATION & FINAL FIELD ALIGNMENT**

### NEW GROUTED BASE PLATES

1. The pump foundation should be located as close to the source of the fluid to be pumped as practical. There should be adequate space for workers to install, operate, and maintain the pump. The foundation should be sufficient to absorb any vibration and should provide a rigid support for the pump and motor. Recommended mass of a concrete foundation should be three times that of the pump, motor and base. Note that foundation bolts are imbedded in the concrete inside a sleeve to allow some movement of the bolt.
2. Level the pump base plate assembly. If the base plate has machined coplanar mounting surfaces, these machined surfaces are to be referenced when leveling the base plate. This may require that the pump and motor be removed from the base plate in order to reference the machined faces. If the base plate is without machined coplanar mounting surfaces, the pump and motor are to be left on the base plate. The proper surfaces to reference when leveling the pump base plate assembly are the pump suction and discharge flanges. **DO NOT** stress the base plate. Do not bolt the suction or discharge flanges of the pump to the piping until the base plate foundation is completely installed. If equipped, use leveling jackscrews to level the base plate. If jackscrews are not provided, shims and wedges should be used (see figure 4). Check for levelness in both the longitudinal and lateral directions. Shims should be placed at all base anchor bolt locations, and in the middle edge of the base if the base is more than five feet long. Do not rely on the bottom of the base plate to be flat. Standard base plate bottoms are not machined, and it is not likely that the field mounting surface is flat.

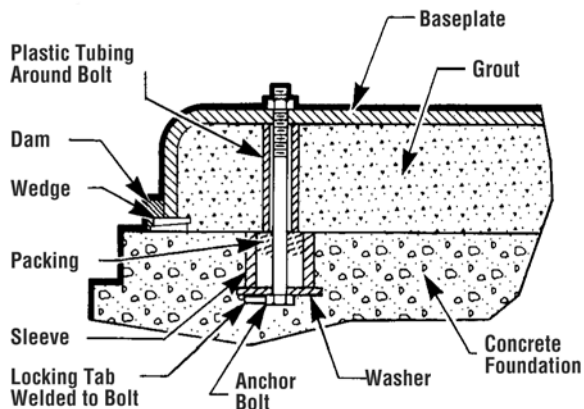
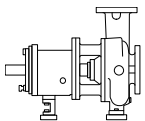

**FIGURE 4 – Base Plate Foundation**

3. After leveling the base plate, tighten the anchor bolts. If shims were used, make sure that the base plate was shimmed near each anchor bolt before tightening. Failure to do this may result in a twist of the base plate, which could make it impossible to obtain final alignment. Check the level of the base plate to make sure that tightening the anchor bolts did not disturb the level of the base plate. If the anchor bolts did change the level, adjust the jackscrews or shims as needed to level the base plate. Continue adjusting the jackscrews or shims and tightening the anchor bolts until the base plate is level.
4. Check initial alignment. If the pump and motor were removed from the base plate proceed with step 5 first, then the pump and motor should be reinstalled onto the base plate using American-Marsh's Factory Preliminary Alignment Procedure, and then continue with the following. As described above, pumps are given a preliminary alignment at the factory. This preliminary alignment is done in a way that ensures that, if the installer duplicates the factory conditions, there will be sufficient clearance between the motor hold down bolts and motor foot holes to move the motor into final alignment. If the pump and motor were properly reinstalled to the base plate or if they were not removed from the base plate and there has been no transit damage, and also if the above steps were done properly, the pump and driver should be within 0.015 in (0.38 mm) FIM (Full Indicator Movement) parallel, and 0.0025 in/in (0.0025 mm/mm) FIM angular. If this is not the case first check to see if the driver mounting fasteners

are centered in the driver feet holes. If not, recenter the fasteners and perform a preliminary alignment to the above tolerances by shimming under the motor for vertical alignment, and by moving the pump for horizontal alignment.

5. Grout the base plate. A non-shrinking grout should be used. Make sure that the grout fills the area under the base plate. After the grout has cured, check for voids and repair them. Jackscrews, shims and wedges should be removed from under the base plate at this time. If they were to be left in place, they could rust, swell, and cause distortion in the base plate.
6. Run piping to the suction and discharge of the pump. There should be no piping loads transmitted to the pump after connection is made. Recheck the alignment to verify that there are no significant loads.
7. Perform final alignment. Check for soft-foot under the driver. An indicator placed on the coupling, reading in the vertical direction, should not indicate more than 0.002 in (0.05 mm) movement when any driver fastener is loosened. Align the driver first in the vertical direction by shimming underneath its feet. When satisfactory alignment is obtained the number of shims in the pack should be minimized. It is recommended that no more than five shims be used under any foot. Final horizontal alignment is made by moving the driver. Maximum pump reliability is obtained by having near perfect alignment. American-Marsh recommends no more than 0.002 in (0.05mm) parallel, and 0.0005 in/in (0.0005 mm/mm) angular misalignment.
8. Operate the pump for at least an hour or until it reaches final operating temperature. Shut the pump down and recheck alignment while the pump is hot. Piping thermal expansion may change the alignment. Realign pump as necessary.

#### EXISTING GROUTED BASE PLATES

When a pump is being installed on an existing grouted base plate, the procedure is somewhat different from the previous section "New Grouted Base Plates."

1. Mount the pump on the existing base plate.
2. Level the pump by putting a level on the discharge flange. If not level, add or delete shims between the foot piece and the bearing housing.
3. Check initial alignment. (Step 4 above)

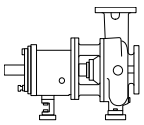

4. Run piping to the suction and discharge flanges of the pump. (Step 6 above)
5. Perform final alignment. (Step 7 above)
6. Recheck alignment after pump is hot. (Step 8 above)

All piping must be independently supported, accurately aligned and preferably connected to the pump by a short length of flexible piping. The pump should not have to support the weight of the pipe or compensate for misalignment. It should be possible to install suction and discharge bolts through mating flanges without pulling or prying either of the flanges. All piping must be tight. Pumps may air-bind if air is allowed to leak into the piping. If the pump flange(s) have tapped holes, select flange fasteners with thread engagement at least equal to the fastener diameter but that do not bottom out in the tapped holes before the joint is tight.

### PIPING CONNECTION – SUCTION & DISCHARGE

All piping must be independently supported, accurately aligned and preferably connected to the pump by a short length of flexible piping. The pump should not have to support the weight of the pipe or compensate for misalignment. It should be possible to install suction and discharge bolts through mating flanges without pulling or prying either of the flanges. All piping must be tight. Pumps may air-bind if air is allowed to leak into the piping. If the pump flange(s) have tapped holes, select flange fasteners with thread engagement at least equal to the fastener diameter but that do not bottom out in the tapped holes before the joint is tight.

air in the process fluid. Vertically mounted concentric reducers are acceptable. In applications where the fluid is completely deaerated and free of any vapor or suspended solids, concentric reducers are preferable to eccentric reducers.

Avoid the use of throttling valves and strainers in the suction line. Startup strainers must be removed shortly after start up. When the pump is installed below the source of supply, a valve should be installed in the suction line to isolate the pump and to permit pump inspection and maintenance. However, never place a valve directly on the suction nozzle of the pump.

Refer to the American-Marsh Pump Engineering Manual and the Centrifugal Pump IOM Section of the Hydraulic Institute Standards for additional recommendations on suction piping.

The curves show maximum allowable suction pressure at various specific gravities. Note that Class 300 flanges may be necessary. Note also that for front vane semi-open impellers the suction pressure is limited only by the pressure/ temperature shown in Figures 2 and 3.

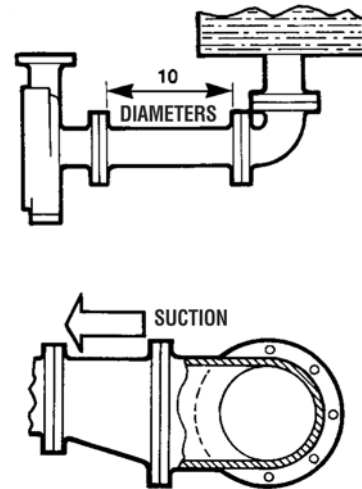

FIGURE 5 – Good Piping Practices

## ! WARNING

**Piping Forces:** Take care during installation and operation to minimize pipe forces and/or moments on the pump casing. Forces and moments must be kept within the limits given in Appendix D.

### SUCTION PIPING

To avoid NPSH and suction problems, suction pipe sizes must be at least as large as the pump suction connection. **Never** use pipe or fittings on the suction that are smaller in diameter than the pump suction size. Figure 5 illustrates the ideal piping configuration with a minimum of 10 pipe diameters between the source and the pump suction. In most cases, horizontal reducers should be eccentric and mounted with the flat side up as shown in figure 5 with a maximum of one pipe size reduction. Never mount eccentric reducers with the flat side down. Horizontally mounted concentric reducers should not be used if there is any possibility of entrained

## ! WARNING

The pressure temperature ratings shown in Figure 2, 3 must not be exceeded.

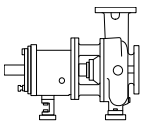

## DISCHARGE PIPING

Install a valve in the discharge line. This valve is required for regulating flow and/or to isolate the pump for inspection and maintenance.

### **WARNING**

*When fluid velocity in the pipe is high, for example, 10 ft/s (3 m/s) or higher, a rapidly closing discharge valve can cause a damaging pressure surge. A dampening arrangement should be provided in the piping.*

## PUMP AND SHAFT ALIGNMENT CHECK

After connecting piping, rotate the pump drive shaft clockwise (view from motor end) by hand several complete revolutions to be sure there is no binding and that all parts are free. Recheck shaft alignment. If piping caused unit to be out of alignment, correct piping to relieve strain on the pump.

## MECHANICAL SEAL

When the pump is intended to be equipped with a mechanical seal, it is American-Marsh's standard practice to install the mechanical seal in the pump prior to shipment. Specific order requirements may specify that the seal be shipped separately, or none be supplied. It is the pump installer's responsibility to determine if a seal was installed. If a seal was supplied but not installed, the seal and installation instructions will be shipped with the pump.

### **WARNING**

*Failure to ensure that a seal is installed may result in serious leakage of the pumped fluid.*

Seal and seal support system must be installed and operational as specified by the seal manufacturer.

The stuffing box/seal chamber/gland may have ports that have been temporarily plugged at the factory to keep out foreign matter. It is the installer's responsibility to determine if these plugs should be removed and external piping connected. Refer to the seal drawings and/or the local American-Marsh representative for the proper connections.

## PACKING

When the pump is intended to be equipped with shaft packing, it is not American-Marsh's standard practice to install the packing in the stuffing box prior to shipment. The packing is shipped with the pump. It is the pump installer's responsibility to install the packing in the stuffing box.

### **WARNING**

*Failure to ensure that packing is installed may result in serious leakage of the pumped fluid.*

## PIPING CONNECTION –SEAL/PACKING SUPPORT SYSTEM

### **WARNING**

*If the pump has a seal support system, it is mandatory that this system be fully installed and operational before the pump is started.*

If packing is used:

**Packing Lubrication** – Water, when compatible with the pumpage, should be introduced into Tap V (Figure 6) at pressure 10 to 15 lbf/in<sup>2</sup> (69 to 103 kPa) above the stuffing box pressure.

The gland should be adjusted to give a flow rate of 40 to 60 drops per minute for clean fluid. For abrasive applications, the regulated flow rate should be 1-2 gpm (0.06-0.13 l/s).

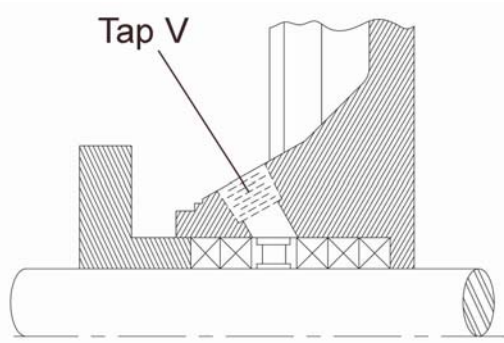
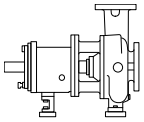
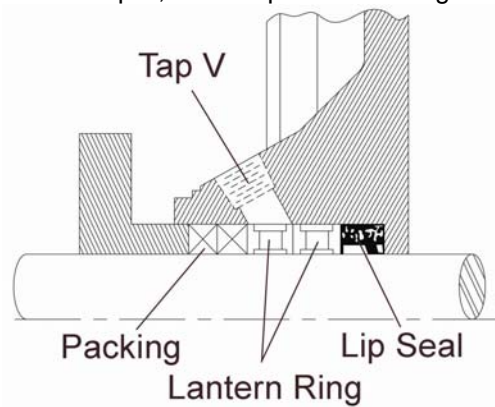

**FIGURE 6**

Grease lubrication, when compatible with the pumpage, may be used. Again, introduced into Tap V. In non-abrasive applications the pumpage itself may be sufficient to lubricate the packing without need for external lines. Tap V should be plugged.

**Abrasive Packing Arrangement** – The installation procedures are the same as the standard packing with some exceptions. A special lip seal is installed first, followed by two lantern ring assemblies, and then two of the packing rings provided (Figure 7).

A flush line from a clean external source should be connected via Tap V, in the top of the stuffing box.



**FIGURE 7**

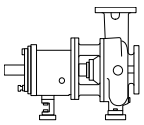

## COUPLING

A direction arrow is cast on the front of the casing and on the Bearing Housing. Make sure the motor rotates in the same direction before coupling the motor to the Pump.

# ! CAUTION

*It is absolutely essential that the rotation of the motor be checked before connecting the shaft coupling. Incorrect rotation of the pump, for even a short time, can dislodge the impeller which may cause serious damage to the pump. All OSG pumps turn clockwise as viewed from the motor end or, conversely, counterclockwise when viewed from the suction end.*

The coupling should be installed as advised by the coupling manufacturer. Pumps are shipped without the spacer installed. If the spacer has been installed to facilitate alignment, then it must be removed prior to checking rotation. Remove protective material from the coupling and any exposed portions of the shaft before installing the coupling.

## PUMP OPERATION

### ROTATION CHECK

# ! CAUTION

*It is absolutely essential that the rotation of the motor be checked before connecting the shaft coupling. Incorrect rotation of the pump, for even a short time, can dislodge and damage the impeller, casing, shaft and shaft seal.*

*All OSG pumps turn clockwise as viewed from the motor end. A direction arrow is cast on the front of the casing. Make sure the motor rotates in the same direction.*

### PRE START-UP CHECKS

Prior to starting the pump it is essential that the following checks are made. These checks are all described in detail in the Maintenance Section of this booklet.

- Pump and Motor properly secured to the base plate
- All fasteners tightened to the correct torques
- Coupling guard in place and not rubbing
- Rotation check, see above

**THIS IS ABSOLUTELY ESSENTIAL.**

- Impeller clearance setting
- Shaft seal properly installed
- Seal support system operational
- Bearing lubrication
- Bearing housing cooling system operational
- Support leg cooling for centerline mounting option operational
- Heating/cooling for jacketed casing/cover operational
- Pump instrumentation is operational
- Pump is primed
- Rotation of shaft by hand

As a final step in preparation for operation, it is important to rotate the shaft by hand to be certain that all rotating parts move freely, and that there are no foreign objects in the pump.

### ENSURING PROPER NPSH<sub>A</sub>

Net Positive Suction Head – Available (NPSH<sub>A</sub>) is the measure of the energy in a liquid above the vapor pressure. It is used to determine the likelihood that a fluid will vaporize in the pump. It is critical because a centrifugal pump is designed to pump a liquid, not a vapor. Vaporization in a pump will result in damage to the pump, deterioration of the Total Differential Head (TDH), and possibly a complete stopping of pumping. Net Positive Suction Head – Required (NPSH<sub>R</sub>) is the decrease of fluid energy between the inlet of the pump, and the point of lowest pressure in the pump. This decrease occurs because of friction losses and fluid accelerations in the inlet region of the pump, and particularly accelerations as the fluid enters the impeller vanes. The value for NPSH<sub>R</sub> for the specific pump purchased is given in the pump data sheet, and on the pump performance curve.

For a pump to operate properly the NPSH<sub>A</sub> must be greater than the NPSH<sub>R</sub>. Good practice dictates that this margin should be at least 5 ft (1.5 m) or 20%, whichever is greater.

# ! CAUTION

*Ensuring that NPSH<sub>A</sub> is larger than NPSH<sub>R</sub> by the suggested margin will greatly enhance pump performance and reliability. It will also reduce the likelihood of cavitation, which can severely damage the pump.*

### MINIMUM FLOW

Minimum continuous stable flow is the lowest flow at which the pump can operate and still conform to the bearing life, shaft deflection and bearing housing vibration limits of ANSI/ASME B73.1M-1991. Pumps

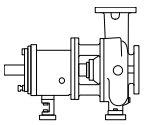

may be operated at lower flows, but it must be recognized that the pump may not conform to one or more of these limits. For example, vibration may exceed the limit set by the ASME standard. The size of the pump, the energy absorbed, and the liquid pumped are some of the considerations in determining the minimum flow.

Typically, limitations of 10% of the capacity at the best efficiency point (BEP) should be specified as the minimum flow.

**Note:** "Minimum intermittent flow" value of 50% of the "minimum continuous flow" as long as that flow is greater than the "minimum thermal flow."

All OSG pumps also have a "Minimum Thermal Flow." This is defined as the minimum flow that will not cause an excessive temperature rise. Minimum Thermal Flow is application dependent.

## **WARNING**

*Do not operate the pump below Minimum Thermal Flow, as this could cause an excessive temperature rise. Contact an American-Marsh Sales Engineer for determination of Minimum Thermal flow.*

### **STARTING THE PUMP AND ADJUSTING FLOW**

1. Open the suction valve to full open position. It is very important to leave the suction valve open while the pump is operating. Any throttling or adjusting of flow must be done through the discharge valve. Partially closing the suction valve can create serious NPSH and pump performance problems.

## **DANGER**

*Never operate pump with both the suction and discharge valves closed. This could cause an explosion.*

2. A standard centrifugal pump will not move liquid unless the pump is primed. A pump is said to be "primed" when the casing and the suction piping are completely filled with liquid. Open discharge valve a slight amount. This will allow any entrapped air to escape and will normally allow

the pump to prime, if the suction source is above the pump. When a condition exists where the suction pressure may drop below the pump's capability, it is advisable to add a low pressure control device to shut the pump down when the pressure drops below a predetermined minimum.

3. All cooling, heating, and flush lines must be started and regulated.
4. Start the driver (typically, the electric motor).
5. Slowly open the discharge valve until the desired flow is reached, keeping in mind the minimum flow restrictions listed above.

## **DANGER**

*It is important that the discharge valve be opened within a short interval after starting the driver. Failure to do this could cause a dangerous buildup of heat, and possibly an explosion.*

6. **Reduced capacity**  
Avoid running a centrifugal pump at drastically reduced capacities or with discharge valve closed for extended periods of time. This can cause severe temperature rise and the liquid in the pump may reach its boiling point. If this occurs, the mechanical seal will be exposed to vapor, with no lubrication, and may score or seize to the stationary parts. Continued running under these conditions when the suction valve is also closed, can create an explosive condition due to the confined vapor at high pressure and temperature. Thermostats may be used to safeguard against over heating by shutting down the pump at a predetermined temperature.

Safeguards should also be taken against possible operation with a closed discharge valve, such as installing a bypass back to the suction source. The size of the bypass line and the required bypass flow rate is a function of the input horsepower and the allowable temperature rise.

7. **Reduced Head**  
Note that when discharge head drops, the pump's flow rate usually increases rapidly. Check motor for temperature rise as this may cause overload. If overloading occurs, throttle the discharge.
8. **Surging Condition**  
A rapidly closing discharge valve can cause a damaging pressure surge. A dampening arrangement should be provided in the piping.

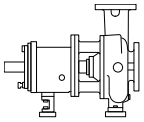

## **OPERATION IN SUB-FREEZING CONDITIONS**

When using the pump in sub-freezing conditions where the pump is periodically idle, the pump should be properly drained or protected with thermal devices which will keep the liquid in the pump from freezing.

## **SHUTDOWN CONSIDERATIONS**

When the pump is being shutdown, the procedure should be the reverse of the start-up procedure. First, slowly close the discharge valve, shutdown the driver, then close the suction valve. Remember, closing the suction valve while the pump is running is a safety hazard and could seriously damage the pump and other equipment.

## **TROUBLESHOOTING**

The following is a guide to troubleshooting problems with American-Marsh pumps. Common problems are analyzed and solutions are offered. Obviously, it is impossible to cover every possible scenario. If a problem exists that is not covered by one of the examples, then contact a local American-Marsh Sales Engineer or Distributor/Representative for assistance.

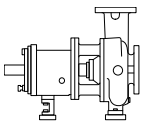

<b>PROBLEM</b>	<b>POSSIBLE CAUSE</b>	<b>RECOMMENDED REMEDY</b>
<b>Problem #1</b> Pump not reaching design flow rate.	1.1 Insufficient NPSH <sub>A</sub> . (Noise may not be present)	Recalculate NPSH available. It must be greater than the NPSH required by pump at desired flow. If not, redesign suction piping, holding number of elbows and number of planes to a minimum to avoid adverse flow rotation as it approaches the impeller.
	1.2 System head greater than anticipated.	Reduce system head by increasing pipe size and/ than or reducing number of fittings. Increase impeller diameter. NOTE: Increasing impeller diameter may require use of a larger motor.
	1.3 Entrained air. Air leak from atmosphere on suction side.	1. Check suction line gaskets and threads for tightness. 2. If vortex formation is observed in suction tank, install vortex breaker. 3. Check for minimum submergence.
	1.4 Entrained gas from process.	Process generated gases may require larger pumps.
	1.5 Speed too low.	Check motor speed against design speed.
	1.6 Direction of rotation wrong.	After confirming wrong rotation, reverse any two of three leads on a three phase motor. The pump should be disassembled and inspected before it is restarted.
	1.7 Impeller too small.	Replace with proper diameter impeller. NOTE: Increasing impeller diameter may require use of a larger motor.
	1.8 Impeller clearance too large.	Reset impeller clearance.
	1.9 Plugged impeller, suction line or casing which may be due to a product or large solids.	1. Reduce length of fiber when possible. 2. Reduce solids in the process fluid when possible. 3. Consider larger pump.
	1.10 Wet end parts (casing cover, impeller) worn, corroded or missing.	Replace part or parts.
<b>Problem #2.0</b> Pump not reaching design head (TDH).	2.1 Refer to possible causes under Problem #1.0.	Refer to remedies listed under Problem #1.0 and #3.0.
<b>Problem #3.0</b> No discharge or flow	3.1 Not properly primed.	Repeat priming operation, recheck instructions. If pump has run dry, disassemble and inspect the pump before operation.
	3.2 Direction of rotation wrong.	After confirming wrong rotation, reverse any two of three leads on a three phase motor. The pump should be disassembled and inspected before operation.

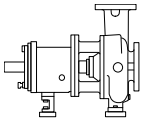

<b>PROBLEM</b>	<b>POSSIBLE CAUSE</b>	<b>RECOMMENDED REMEDY</b>
<b>Cont. Problem #3.0</b> No discharge or flow	3.3 Entrained air. Air leak from atmosphere on suction side.	Refer to recommended remedy under Problem #1.0, Item #1.3.
	3.4 Plugged impeller, suction line or casing which may be due to a fibrous product or large solids.	Refer to recommended remedy under Problem #1.0, Item #1.9.
	3.5 Damaged pump shaft, impeller.	Replace damaged parts.
<b>Problem #4.0</b> Pump operates for short period, then loses prime.	4.1 Insufficient NPSH.	Refer to recommended remedy under Problem #1.0, Item #1.1.
	4.2 Entrained air. Air leak from atmosphere on suction side.	Refer to recommended remedy under Problem #1.0, Item #1.3.
<b>Problem #5.0</b> Excessive noise from wet end.	5.1 Cavitation - insufficient NPSH available.	Refer to recommended remedy under Problem #1.0, Item #1.1.
	5.2 Abnormal fluid rotation due to complex suction piping.	Redesign suction piping, holder number of elbows and number of planes to a minimum to avoid adverse fluid rotation as it approaches the impeller.
	5.3 Impeller rubbing.	1. Check and reset impeller clearance. 2. Check outboard bearing assembly for axial end play.
<b>Problem #6.0</b> Excessive noise from power end.	6.1 Bearing contamination appearing on the raceways as scoring, pitting, scratching, or rusting caused by adverse environment and entrance of abrasive contaminants from atmosphere.	1. Work with clean tools in clean surroundings. 2. Remove all outside dirt from housing before exposing bearings. 3. Handle with clean dry hands. 4. Treat a used bearing as carefully as a new one. 5. Use clean solvent and flushing oil. 6. Protect disassembled bearing from dirt and moisture. 7. Keep bearings wrapped in paper or clean cloth while not in use. 8. Clean inside of housing before replacing bearings. 9. Check oil seals and replace as required. 10. Check all plugs and tapped openings to make sure that they are tight.
	6.2 Brinelling of bearing identified by indentation on the ball races, usually caused by incorrectly applied forces in assembling the bearing or by shock loading such as hitting the bearing or drive shaft with a hammer.	When mounting the bearing on the drive shaft use a proper size ring and apply the pressure against the inner ring only. Be sure when mounting a bearing to apply the mounting pressure slowly and evenly.

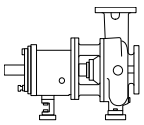

<b>PROBLEM</b>	<b>POSSIBLE CAUSE</b>	<b>RECOMMENDED REMEDY</b>
<b>Cont. Problem #6.0</b> Excessive noise from power end.	6.3 False brinelling of bearing identified again by either axial or circumferential indentations usually caused by vibration of the balls between the races in a stationary bearing.	1. Correct the source of vibration. 2. Where bearings are oil lubricated and employed in units that may be out of service for extended periods, the drive shaft should be turned over periodically to re-lubricate all bearing surfaces at intervals of one-to three months.
	6.4 Thrust overload on bearing identified by flaking ball path on one side of the outer race or in the case of maximum capacity bearings, may appear as a spalling of the races in the vicinity of the loading slot. (Please note: maximum capacity bearings are not recommended in OSG pumps.) These thrust failures are caused by improper mounting of the bearing or excessive thrust loads.	1. Follow correct mounting procedures for bearings.
	6.5 Misalignment identified by fracture of ball retainer or a wide ball path on the inner race and a narrower cocked ball path on the outer race. Misalignment is caused by poor mounting practices or defective drive shaft. For example bearing not square with the centerline or possibly a bent shaft due to improper handling.	Handle parts carefully and follow recommended mounting procedures. Check all parts for proper fit and alignment.
	6.6 Bearing damaged by electric arcing identified as electro-etching of both inner and outer ring as a pitting or cratering. Electrical arcing is caused by a static electrical charge emanating from belt drives, electrical leakage or short circuiting.	1. Where current shunting through the bearing cannot be corrected, a shunt in the form of a slip ring assembly should be incorporated. 2. Check all wiring, insulation and rotor windings to be sure that they are sound and all connections are properly made. 3. Where pumps are belt driven, consider the elimination of static charges by proper grounding or consider belt material that is less generative.

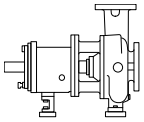

<b>PROBLEM</b>	<b>POSSIBLE CAUSE</b>	<b>RECOMMENDED REMEDY</b>
Cont.: <b>Problem #6.0</b> Excessive noise from power end.	6.7 Bearing damage due to improper lubrication, identified by one or more of the following: 1. Abnormal bearing temperature rise. 2. A stiff cracked grease appearance. 3. A brown or bluish discoloration of the bearing races.	1. Be sure the lubricant is clean. 2. Be sure proper amount of lubricant is used. The constant level oiler supplied with OSG pumps will maintain the proper oil level if it is installed and operating properly. In the case of greased lubricated bearings, be sure that there is space adjacent to the bearing into which it can rid itself of excessive lubricant, otherwise the bearing may overheat and fail prematurely. 3. Be sure the proper grade of lubricant is used.

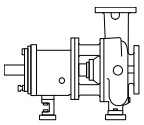

## MAINTENANCE

### PREVENTIVE MAINTENANCE

The following sections of this manual give instructions on how to perform a complete maintenance overhaul. However, it is also important to periodically repeat the "Pre start-up checks" listed on page 13. These checks will help extend pump life as well as the length of time between major overhauls.

### NEED FOR MAINTENANCE RECORDS

A procedure for keeping accurate maintenance records is a critical part of any program to improve pump reliability. There are many variables that can contribute to pump failures. Often long term and repetitive problems can only be solved by analyzing these variables through pump maintenance records.

### MAINTENANCE SCHEDULE

#### ROUTINE MAINTENANCE

- Bearing lubrication
- Seal monitoring
- Vibration analysis
- Discharge pressure
- Temperature monitoring

#### ROUTINE INSPECTIONS

- Check level and condition of oil through sight glass on bearing frame.
- Check for unusual noise, vibration and bearing temperatures.
- Inspect pump and piping for leaks.
- Check seal chamber/stuffing box for leakage.
- Check mechanical seal for leakage.
- Check packing for excessive leakage see requirements in Packing Section on page 11 for packing gland adjustment.

#### 3 MONTH INSPECTIONS

- Check the foundation and the hold-down bolts for tightness.
- If the pump has been left idle, check the packing. Replace if required.
- Oil should be changed at least every 3 months (2000 hours) or more often if there are any adverse atmospheric conditions or other conditions which might contaminate or break down the oil. If it is cloudy or contaminated as seen by inspection through the sight glass, it should be changed immediately.
- Check the shaft alignment. Realign if required.

### ANNUAL INSPECTIONS

- Check the pump capacity, pressure and power. If the pump performance does not satisfy your process requirements, and the process requirements have not changed, the pump should be disassembled, inspected, and worn parts should be replaced. Otherwise, a system inspection should be done.

### INSPECTION INTERVALS

Inspection intervals should be shortened appropriately if the pumpage is abrasive and/or corrosive or if the environment is classified as potentially explosive.

### NEED FOR CLEANLINESS

One of the major causes of pump failure is the presence of contaminants in the bearing housing. This contamination can be in the form of moisture, dust, dirt and other solid particles such as metal chips. Contamination can also be harmful to the mechanical seal (especially the seal faces) as well as other parts of the pumps. For example, dirt in the impeller threads could cause the impeller to not be seated properly against the shaft. This, in turn, could cause a series of other problems. For these reasons, it is very important that proper cleanliness be maintained. Some guidelines are listed below.

After draining the oil from the bearing housing, periodically send it out for analysis. If it is contaminated, determine the cause and correct. The work area should be clean and free from dust, dirt, oil, grease, etc. Hands and gloves should be clean. Only clean towels, rags, and tools should be used.

### DISASSEMBLY

Refer to the parts list shown in Figure 21, 22, 23 & 24 for item number references used throughout this section.

1. Before performing any maintenance, disconnect the driver from its power supply and lock it off line.

**! DANGER**

*Lock out power to driver to prevent personal injury.*

2. Close the discharge and suction valves, and drain all liquid from the pump.
3. Close all valves on auxiliary equipment and piping, then disconnect all auxiliary piping.
4. Decontaminate the pump as necessary. *If American-Marsh pumps contain dangerous chemicals, it is important to follow plant safety guidelines to avoid personal injury or death.*

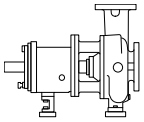

5. Remove the coupling guard.
6. Remove the spacer from the coupling.
7. Remove casing fasteners (#383B).
8. Remove the fasteners holding the bearing housing foot to the base plate.
9. Remove the power end, rear cover, and seal chamber assembly from the casing. Tighten jack screws evenly to remove the back pull-out assembly. Discard the casing/cover gasket (#351A).

**NOTE:** Mark all shims from under power frame foot. Save for reassembly.

## DANGER

*The power end and rear cover assembly is heavy. It is important to follow plant safety guidelines when lifting it.*

10. Transport the assembly to the maintenance shop.
11. Remove the coupling hub from the pump shaft.  
**NOTE:** Blue and scribe shaft for relocating the coupling hub for reassembly.
12. Using the shaft key (#125A) and with the wrench handle pointing to the left when viewed from the impeller end, grasp the impeller (#11A) firmly with both hands (wear heavy gloves), by turning the impeller in the clockwise direction move the wrench handle to the 11:00 o'clock position and then spin the impeller quickly in a counterclockwise direction so that the wrench makes a sudden impact with a hard surface on the bench. After several sharp raps, the impeller should be free. Unscrew the impeller and remove from the shaft. Discard the impeller gasket (#331C).

## CAUTION

*Do not apply heat to the impeller. If liquid is present, an explosion could occur.*

13. Remove the seal or packing gland nuts (#72D).
14. Remove the two cap screws (#383B) which attach the rear cover plate to the adapter. Carefully remove the rear cover plate (#2D).
15. If a cartridge type mechanical seal is used, loosen the set screws which lock the unit to the shaft and remove the complete seal assembly.

- If the seal is to be reused, the spacing clips or tabs should be reinstalled prior to loosening the set screws. This will ensure that the proper seal compression is maintained.
16. If a component type inside mechanical seal (#331B) is used, loosen the set screws on the rotating unit and remove it from the shaft.
  17. Then pull the gland (#71A) and stationary seat off the shaft. Remove the stationary seat from the gland. Discard all O-rings and gaskets.
  18. If a component type outside mechanical seal is used, remove the gland and the stationary seat. Remove the stationary seat from the gland. Loosen the set screws in the rotating unit and remove it. Discard all O-rings and gaskets.
  19. If packing (#331A) is used, remove it and the seal cage (lantern ring)(#73A). Remove the gland (#71A).
  20. If the pump has a hook type sleeve (#42A) it can now be removed.
  21. If the power end is oil lubricated, remove the drain plug (#411B) and drain the oil from the bearing housing (#2B).
  22. If the pump has lip seals, a deflector (#104P) will be present. Remove it.
  23. For MTX, LTX, and XLTX models remove dowel pins (#93P). and bolts (#387B), remove frame adapter (#108), and remove and discard gasket (#331D).
  24. Remove inboard labyrinth oil seal (#104P). It is an O-ring fit into the bearing frame.

### **Disassembly of Power End – STX & MTX Models**

25. Remove clamp screws (#387B) evenly, this will start bearing housing (#85N) out of bearing frame (#2B).
26. Remove the shaft assembly from the bearing frame (#2B)
27. Remove jack screws (#387B) with nuts (#387G).
28. Remove bearing housing O-ring (#359A).
29. Remove outboard bearing retaining snap ring (#201C).
30. Remove bearing housing (#85N) from shaft (#41A) with bearings (81N, 81P).
31. Remove outboard labyrinth seal (#104N) from bearing housing (#85N).
32. The bearing locknut (#91N) and lock washer (#89N) may now be removed from the shaft (#41A). Discard the lock washer.
33. Remove inboard and outboard bearings. An arbor or hydraulic press may be used to remove the bearings (#81N and #81P) from the shaft (#41A). It is extremely important to apply even pressure to the inner bearing race only. Never apply pressure to the outer race as this exerts excess load on the balls and causes damage.

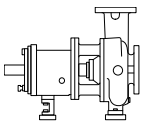

## **CAUTION**

*Applying pressure to the outer race could permanently damage the bearings.*

### **Disassembly of Power End – LTX Models**

34. Remove clamp screws (#384B). Back off jam nuts (#387G). Tighten jack screws (#387B) evenly; this will start bearing housing (#85N) out of bearing frame (#2B).
35. Remove the shaft assembly from the bearing frame (#2B)
36. Remove jack screws (#387B) with nuts (#387G).
37. Remove clamp ring screws (#236A). Separate clamp ring (#253B) from bearing housing (#85N).
38. Remove bearing housing (#85N) from shaft (#41A) with bearing (#81N, #81P).
39. Remove bearing housing O-ring (#359A).
40. Remove inboard bearing (#81P) per #32 above.
41. The bearing locknut (#124) and lock washer (#125) may now be removed from the shaft (#105). Discard the lock washer.
42. Remove outboard labyrinth seal (#104N) from bearing housing (#85N).

### **Disassembly of Power End – XLTX Models**

43. Remove bearing frame to frame foot bolts (#136B) and frame foot (#2C).
44. Remove clamp screws (#384B). Back off jam nuts (#387G). Tighten jack screws (#387B) evenly; this will start bearing housing (#85N) out of bearing frame (#2B).
45. Remove the shaft assembly from the bearing frame (#2B)
46. Remove jack screws (#387B) with nuts (#387G).
47. Remove bearing housing O-ring (#359A).
48. Remove inboard bearing (#81P) per #32 above.
49. Remove bolts (#388D), bearing end cover (#85N) and gasket (360C).
50. Remove outboard labyrinth seal (#104N) from end cover (#85N).
51. Remove bearing housing (#85N) from shaft (#41A) with bearing (#81N).
52. The bearing locknut (#124) and lock washer (#125) may now be removed from the shaft (#105). Discard the lock washer.
53. Remove outboard bearing (#81N) per #32 above.
54. If lip seals (#118) and (#129) are used, they should be removed from the bearing housing and adapter and discarded. If bearing isolators are used, refer to Appendix C.

55. If magnetic seals are used, maintain the seals as specified by the manufacturer.
56. If present, the Trico oiler (#133) (Figure 28) should be removed from the bearing housing.
57. The sight gage (#200) (Figure 29) should be removed from the bearing housing.

## **CLEANING/INSPECTION**

All parts should now be thoroughly cleaned and inspected. New bearings, O-rings, gaskets, and lip seals should be used. Any parts that show wear or corrosion should be replaced with new genuine American-Marsh parts.

## **WARNING**

*It is important that only non-flammable, non-contaminated cleaning fluids are used. These fluids must comply with plant safety and environmental guidelines.*

## **CRITICAL MEASUREMENT AND TOLERANCES**

To maximize reliability of pumps, it is important that certain parameters and dimensions are measured and maintained within specified tolerances. Please refer to Appendix A for a summary of these various physical parameters and the associated tolerances which are vital for maximizing pump reliability. It is very important that all parts be checked as specified in Appendix A. Any parts that do not conform to the specifications should be replaced with new American-Marsh parts.

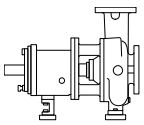

## ASSEMBLY

**Note:** Refer to Figure 8 for all bolt torque information.

It is very important that all pipe threads be sealed properly. PTFE tape provides a very reliable seal over a wide range of fluids, but it has a serious shortcoming if not used properly. If, during application to the threads, the tape is wrapped over the end of the male thread, strings of the tape will be formed off when threaded into the female fitting. This string can then tear away and lodge in the piping system. If this occurs in the seal flush system, small orifices can become blocked effectively shutting off flow. For this reason, American-

Marsh does not recommend the use of PTFE tape as a thread sealant.

American-Marsh has investigated and tested alternate sealants and has identified two that provide an effective seal, have the same chemical resistance as the tape, and will not plug flush systems. These are La-co SlicTite and Bakerseal. Both products contain finely ground PTFE particles in an oil based carrier. They are supplied in a paste form which is brushed on the male pipe threads. American-Marsh recommends using one of these paste sealants.

Full thread length engagement is required for all fasteners.

Frame	Location	STX, MTX	LTX	XLTX
Various	Frame to Adapter	30 ft-lb – 40 Nm	30 ft-lb – 40 Nm	30 ft-lb – 40 Nm
236A	Bearing Clamp Ring Bolts, Duplex Bearing Only	17 in-lb – 1.9 Nm	83 in-lb – 9.4 Nm	N/A
371C	Bearing End Cover Bolts	N/A	N/A	12 ft-lb – 16 Nm
265	Dynamic Seal Capscrews	83 in-lb – 9.4 Nm	83 in-lb – 9.4 Nm	12 ft-lb – 16 Nm

Item	Description	8" STX (1/2" Dia. Bolts)	6" STX, MTX, LTX and XLTX (5/8" Dia. Bolts)
370	Casing Bolts for Ductile Iron casing w/ standard bolts	30 ft-lb – 40 Nm	59 ft-lb – 80 Nm
370	Casing Bolts for Alloy casing w/ 304SS or 316SS bolts	54 ft-lb – 73 Nm	107 ft-lb – 145 Nm
370	Casing Bolts for 300 lb. casings with grade B7 bolts	87 ft-lb – 118 Nm	173 ft-lb – 235 Nm

**Note:** 1.) For lubricated threads, use 75% of the values given. 2.) Gasket joint torque values are for un-filled PTFE gaskets. Harder gasket materials may require more torque to seal. Exceeding metal joint torque values is not recommended.

**FIGURE 8 – Recommended Bolt Torques (US & Metric Units)**

## POWER END ASSEMBLY

### BEARING INSTALLATION

Mounting of bearings on shafts must be done in a clean environment. Bearing and power end life can be drastically reduced if even very small foreign particles work their way into the bearings.

Bearings should be removed from their protective packaging only immediately before assembly to limit exposure to possible contamination. After removing the

packaging they should only come in contact with clean hands, fixtures, tools and work surfaces.

The chart shown in Figure 9 gives the SKF part numbers for bearings in American-Marsh OSG pumps. Note that the term “inboard bearing” refers to the bearing nearest to the casing. “Outboard bearing” refers to the bearing nearest to the motor.

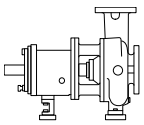

Group	Type of Bearings	Inboard Single Row, Deep Groove <sup>⑤</sup>	Outboard Double Row, Angular Contact, Deep Groove <sup>⑤</sup>	Optional Outboard Duplex Angular Contact <sup>⑤</sup>
STX	Oil bath/mist – Open <sup>①</sup> Regreasable – Single Shielded <sup>②</sup> Greased for life – Double Shielded <sup>③</sup> Sealed for life – Double Sealed <sup>④</sup>	6207-C3 6207-ZC3 6207-2ZC3 6207-2RSIC3	5306-AC3 5306-AZC3 5306-A2ZC3 5306-A2RSC3	7306-BECBY NA <sup>⑥</sup> NA <sup>⑦</sup> NA <sup>⑦</sup>
MTX	Oil bath/mist – Open <sup>①</sup> Regreasable – Single Shielded <sup>②</sup> Greased for life – Double Shielded <sup>③</sup> Sealed for life – Double Sealed <sup>④</sup>	6309-C3 6309-ZC3 6309-2ZC3 6309-2RSIC3	5309-AHC3 5309-AZC3 5309-A2ZC3 5309-A2RSC3	7309-BECBY NA <sup>⑥</sup> NA <sup>⑦</sup> NA <sup>⑦</sup>
LTX	Oil bath/mist – Open <sup>①</sup> Regreasable – Single Shielded <sup>②</sup> Greased for life – Double Shielded <sup>③</sup> Sealed for life – Double Sealed <sup>④</sup>	6311-C3 6311-ZC3 6311-2ZC3 6311-2RSIC3	N/A	7310-BECBY NA <sup>⑥</sup> NA <sup>⑦</sup> NA <sup>⑦</sup>
XLTX	Oil bath/mist – Open <sup>①</sup> Regreasable – Single Shielded <sup>②</sup> Greased for life – Double Shielded <sup>③</sup> Sealed for life – Double Sealed <sup>④</sup>	6313-C3 6313-ZC3 6313-2ZC3 6313-2RSIC3	5313-AC3 5313-AZC3 5313-A2ZC3 5313-A2RSC3	7313-BECBY NA <sup>⑥</sup> NA <sup>⑦</sup> NA <sup>⑦</sup>

**FIGURE 9 – AMP OSG Bearings**

- ① These bearings are open on both sides. They are lubricated by oil bath or oil mist.
- ② These bearings are pre-greased by American-Marsh. Replacement bearings will generally not be pre-greased, so grease must be applied by the user. They have a single shield, which is located on the side next to the grease buffer, or reservoir. The bearings draw grease from the reservoir as it is needed. The shield protects the bearing from getting too much grease, which would generate heat. The grease reservoir is initially filled with grease by American-Marsh. Lubrication fittings are provided, to allow the customer to periodically replenish the grease, as recommended by the bearing and/or grease manufacturer.
- ③ These bearings are shielded on both sides. They come pre-greased by the bearing manufacturer. The user does not need to re-grease these bearings. The shields do not actually contact the bearing race, so no heat is generated.
- ④ These bearings are sealed on both sides. They come pre-greased by the bearing manufacturer. The user does not need to re-grease these bearings. The seals physically contact and rub against the bearing race, which generates heat. These bearings are not recommended at speeds above 1750 RPM.
- ⑤ The codes shown are SKF codes. Inboard and outboard bearings have the C3, greater than “Normal” clearance. These clearances are recommended by SKF to maximize bearing life.
- ⑥ Re-greasable – Single Shielded bearings are not available in the duplex configuration; however, open oil bath-type bearings can be used for the re-greasable configuration. These bearings must be pre-greased during assembly. Lubrication fittings are provided, to allow the user to periodically replenish the grease, as recommended by the bearing and/or grease manufacturer.
- ⑦ Not available.

**BEARING INSTALLATION FOR POWER END ASSEMBLY (CONT'D)**

The bearings must be positioned against the shoulder as shown in Figure 10. If the power end is equipped with single shield re-greaseable bearings, the shields should be oriented as shown in Figure 10.

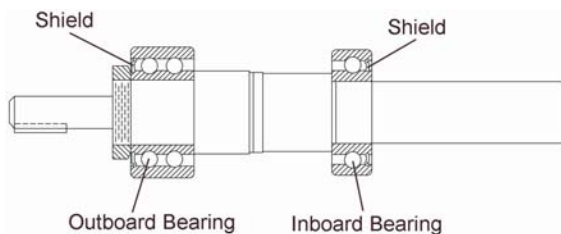

**FIGURE 10 – Shielded Bearing Arrangement**

Both bearings have a slight interference fit which requires that they be pressed on the shaft with an arbor

or hydraulic press. A chart giving bearing fits is shown in Figure 11. Even force should be applied to the inner race only. Never press on the outer race, as the force will damage the balls and races. An alternate method of installing bearings is to heat the bearings to 200°F (93°C) in an oven or induction heater. Then place them quickly in position on the shaft.

CAUTION

*Never heat the bearings above 230°F (110°C). To do so will likely cause the bearing fits to permanently change, leading to early failure.*

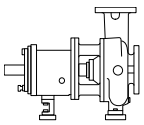

		STX	MTX	LTX
OB brg ID to shaft OD	Bearing to Shaft Fit	1.1811/1.1815 1.1807/1.1812 0.008T/0.0001T	1.7717/1.7722 1.7712/1.7718 0.0010T/0.0001T	1.9685/1.9690 1.9680/1.9686 0.0010T/0.0001T
IB brg ID to shaft OD	Bearing to Shaft Fit	1.3780/1.3785 1.3775/1.3781 0.0010T/0.0001T	1.7717/1.7722 1.7712/1.7718 0.0010T/0.0001T	2.1654/2.1660 2.1648/2.1655 0.0012T/0.0001T
OB brg OD to hsg ID	Bearing Housing Fit	2.8346/2.8346 2.8341/2.8353 0.0012L/0.0000L	3.9370/3.9370 3.9364/3.9379 0.0015L/0.0000L	4.3307/4.3307 4.3301/4.3316 0.0015L/0.0000L
IB brg OD to hsg ID	Bearing Housing Fit	2.8346/2.8346 2.8341/2.8353 0.0012L/0.0000L	3.9370/3.9370 3.9364/3.9379 0.0015L/0.0000L	4.7244/4.7244 4.7238/4.7253 0.0015L/0.0000L

FIGURE 11 – Bearing Fits

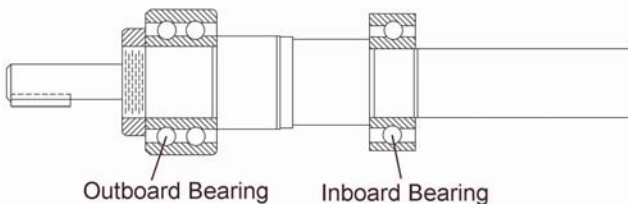

FIGURE 12 – Bearing Designations

#### Assembly of Rotating Element and Bearing Frame For STX and MTX Models

1. Install outboard bearing (#81N) on shaft (#41A) per bearing installation instructions above.
2. Place lockwasher (#89N) on shaft (#41A). Place tang of lockwasher in keyway of shaft.
3. Thread locknut (#91N) onto shaft (#41A). Tighten locknut until snug. Bend any tang of lockwasher into a slot of locknut (#91N).
4. Place bearing retaining ring (#201C) over shaft (#41A). Flat side facing bearing.
5. Install inboard bearing (#81P) on shaft (#41A) per bearing installation instructions above.
6. Install new O-ring (#359A).
7. Coat outside of outboard bearing (#81N) and bearing housing (#85N) bore with oil.
8. Install bearing housing (#85N) onto shaft/bearing assembly. **Do not force assembly together.**
9. Insert retaining ring (#201C) into groove in housing (#85N) bore. Check shaft for free turning. The space between the ends of retaining ring should be located in the oil return groove so as not to obstruct oil flow.
10. Install outboard labyrinth oil seal (#104N) into bearing housing (#85N). It is an O-ring fit. Position the labyrinth seal drain slots at the bottom 6 o'clock position. Refer to Appendix C for details.
11. Coat outside of bearing housing (#85N) with oil.

12. Coat all internal surfaces of bearing frame (#2B) with oil.
13. Install shaft assembly into frame (#2B), making sure to leave approximately 0.125 in. clearance between the face of the bearing housing and bearing frame. Check shaft for free turning.
14. Install clamping bolts (#384B) into bearing housing (#85N). Hand tighten.
15. Install jacking bolts (#387B) with locking nuts (#387G) into housing (#85N). Hand tighten.

#### Assembly of Rotating Element and Bearing Frame For LTX Models

1. Install oil flinger (#248) on shaft (#41A) if removed.
2. Install outboard bearing (#81N) on shaft (#41A) per bearing installation instructions above.
3. Place lockwasher (#89N) on shaft (#41A). Place tang of lockwasher in keyway of shaft.
4. Thread locknut (#91N) onto shaft (#41A). Tighten locknut until snug. Bend any tang of lockwasher into a slot of locknut (#91N).
5. Install inboard bearing (#81P) on shaft (#41A) per bearing installation instructions above.
6. Coat outside of outboard bearing (#81N) and bearing housing (#85N) bore with oil.
7. Install bearing housing (#85N) onto shaft/bearing assembly. **Do not force assembly together.**
8. Install clamp ring bolts (#236A). Check shaft for free turning. Refer to figure 8 for bolt torque values.
9. Install new O-ring (#359A).
10. Install outboard labyrinth oil seal (#104N) into bearing housing (#85N). It is an O-ring fit. Position the labyrinth seal drain slots at the bottom 6 o'clock position. Refer to Appendix C for details.
11. Coat outside of bearing housing (#85N) with oil.
12. Coat all internal surfaces of bearing frame (#2B) with oil.
13. Install shaft assembly into frame (#2B), making sure to leave approximately 0.125 in. clearance between the face of the bearing housing and bearing frame. Check shaft for free turning.
14. Install clamping bolts (#384B) into bearing housing (#85N). Hand tighten.
15. Install jacking bolts (#387B) with locking nuts (#387G) into housing (#85N). Hand tighten.

#### Assembly of Rotating Element and Bearing Frame For XLTX Models

1. Install outboard bearing (#81N) on shaft (#41A) per bearing installation instructions above.

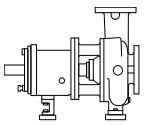

2. Place lockwasher (#89N) on shaft (#41A). Place tang of lockwasher in keyway of shaft.
3. Thread locknut (#91N) onto shaft (#41A). Tighten locknut until snug. Bend any tang of lockwasher into a slot of locknut (#91N).
4. Coat outside of outboard bearing (#81N) and bore of bearing housing (#85N) with oil.
5. Install bearing housing (#85N) onto shaft/bearing assembly. **Do not force assembly together.**
6. Install gasket (#360C), end cover (#85N), bolts (#388D). Refer to Figure 8 for bolt torque values. Check shaft for free turning.
7. Install inboard bearing (#81P) on shaft(#41A) per bearing installation instructions above.
8. Install new O-ring (#359A).
9. Install outboard labyrinth oil seal (#104N) into bearing housing (#85N). It is an O-ring fit. Position the labyrinth seal drain slots at the bottom 6 o'clock position. Refer to Appendix C for details.
10. Coat outside of bearing housing (#85N) with oil.
11. Coat all internal surfaces of bearing frame (#2B) with oil.
12. Install shaft assembly into frame (#2B), making sure to leave approximately 0.125 in. clearance between the face of the bearing housing and bearing frame. Check shaft for free turning.
13. Install clamping bolts (#384B) into bearing housing (#85N). Hand tighten.
14. Install jacking bolts (#387B) with locking nuts (#387G) into housing (#85N). Hand tighten.
15. Attach bearing frame foot (#2C) with bolts (#136B). Hand tighten.

## ALL MODELS

1. Support frame assembly in horizontal position.
2. Check shaft end play. Move shaft forward then backward by hand, noting indicator movement. If total indicator reading is greater than values in Appendix A, disassemble and determine cause.
3. Check shaft/sleeve runout. Put on shaft sleeve (#42A) if used, and thread on impeller, hand tight. Rotate shaft 360 degrees. If total indicator reading is greater than 0.002 in., disassemble and determine cause. Remove impeller and shaft sleeve.
4. Check frame face run out. Rotate shaft so indicator rides along the fit for 360 degrees. If total indicator reading is greater than 0.001 in. disassemble and determine cause.
5. Place manila gasket (#331D) on frame (#2B).
6. Install frame adapter (#108), onto frame assembly. Align bolt holes and dowel locations with those on frame.
7. Install dowel pins (#93P) and bolts (#387B). Tighten bolts to Figure 8 torque specifications in a crisscross pattern.
8. Check adapter fits. Rotate shaft through 360 degrees. If total indicator reading is greater than 0.005 in., determine the cause and correct before proceeding.
9. Install inboard labyrinth oil seal (104P) into adapter (#108) / BEARING FRAME (#2B). It is an O-ring fit. Position the labyrinth seal drain slots at the bottom 6 o'clock position. Refer to Appendix C for details

## Pumps With Mechanical Seals

1. Install seal chamber cover or backplate (#2D) with nuts (#385E).
2. Check seal chamber cover run-out. Rotate shaft 360 degrees. If total indicator reading is greater than 0.005 in., determine cause and correct before proceeding.
3. Install shaft sleeve (#42A) if used. Make sure sleeve is fully seated.
4. **Models STX, MTX, & LTX** – Install impeller (#11A) with O-ring (#331C).
5. **Model XLTX** – Install the impeller (#11A) without the O-ring (#331C) and Teflon washer (#428D) on plug (#458Y).
6. Put shaft wrench and coupling key on shaft. When impeller (#11A) makes firm contact with sleeve (#42A), raise shaft wrench (counterclockwise, viewed from impeller end of shaft) off bench and slam it down (clockwise, viewed from impeller end of shaft). A few sharp raps will tighten impeller (#11A) properly.
7. Loosen clamp bolts (#384B), and jacking bolts (#387B). Measure gap between impeller (#11A)

## Duplex Angular Contact Bearings

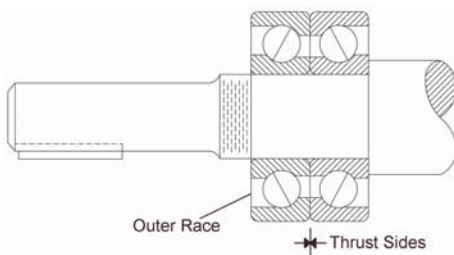

**FIGURE 13 – Duplex Angular Contact Bearings**

Duplex angular contact bearings must be mounted back to back with the wider thrust sides of the outer races in contact with each other as shown in Figure 13. Only bearings designed for universal mounting should be used. SKF's designation is "BECB". NTN's designation is "G".

Note: A special shaft is required when using duplex angular contact bearings.

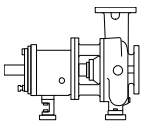

and seal chamber/stuffing box cover (#2D) with feeler gauge. When 0.030 in. clearance is reached, tighten clamp bolts (#384B), jacking bolts (#387B), and locking nuts (#387G). This approximates the impeller position when seat at 0.015 in. from casing. Final impeller adjustment must be made after installation into casing.

8. Check impeller (#11A) runout. Check vane tip to vane tip. If total indicator reading I greater than 0.005 in., determine cause and correct before proceeding.
9. Blue the shaft sleeve (#42A) or shaft (#41A) if no sleeve is used. Scribe a mark at gland gasket face of seal chamber/stuffing box cover (#2D). This will be the datum for installation of the mechanical seal.
10. Remove the impeller (#11A) and shaft sleeve (#42A) if used.
11. Remove the seal chamber cover or the backplate (#2D).
12. Install stationary seat into gland (#71A) per seal manufacturer's instructions.
13. Slide gland (#71A) with stationary seat over shaft, up to adapter face.
14. Install mechanical seal on shaft (#41A) or shaft sleeve (#42A) per seal manufacturer's instructions. Install shaft sleeve (#42A) if used (with seal).
15. Install seal chamber cover (#2D) with nuts (#385E).
16. Install impeller (#11A) with new O-ring (#331C). Put shaft wrench and coupling key on shaft. When impeller (#11A) makes firm contact with sleeve (#42A), raise shaft wrench (counterclockwise, viewed from impeller end of shaft) off bench and slam it down (clockwise, viewed from impeller end of shaft). A few sharp raps will tighten impeller (#11A) properly. Be sure to use a properly balanced impeller.
17. Install gland (#71A) with nuts (355).

### Pumps With Packing

1. Install stuffing box cover (#2D) with nuts (#385E).
2. Check stuffing box run-out. Rotate shaft 360 degrees. If total indicator reading is greater than 0.005 in., determine cause and correct before proceeding.
3. Install shaft sleeve (#42A) if used. Make sure sleeve is fully seated.
4. Install impeller (#11A) with new O-ring (#331C). Put shaft wrench and coupling key on shaft. When impeller (#11A) makes firm contact with sleeve (#42A), raise shaft wrench (counterclockwise, viewed from impeller end of shaft) off bench and slam it down (clockwise,

viewed from impeller end of shaft). A few sharp raps will tighten impeller (#11A) properly. Be sure to use a properly balanced impeller.

5. Loosen clamp bolts (#384B), and jacking bolts (#387B). Measure gap between impeller (#11A) and seal chamber/stuffing box cover (#2D) with feeler gauge. When 0.030 in. clearance is reached, tighten clamp bolts (#384B), jacking bolts (#387B), and locking nuts (#387G). This approximates the impeller position when seat at 0.015 in. from casing. Final impeller adjustment must be made after installation into casing.
6. Check impeller (#11A) runout. Check vane tip to vane tip. If total indicator reading I greater than 0.005 in., determine cause and correct before proceeding.
7. Install packing and gland.

### Reinstall Back Pull-Out Assembly

1. Clean casing fit and install casing gasket (351) in place on seal chamber/stuffing box cover.
2. Loosen clamping bolts (#384B) and jacking bolts (#387B) on bearing housing.
3. Install back pull-out assembly in casing.
4. Install casing bolts (#383B), finger tight. Casing bolts (#383B) may be coated with anti-galling compound to aid disassembly. Tighten the casing bolts per Figure 8 torque values. Install casing jack screws (418), snug tight.
5. **Do not overtighten casing jack screws (418).**
6. Replace shims under frame foot and tighten frame foot to baseplate. To insure that the proper shim is used, a dial indicator should be mounted to measure distance between top of frame and baseplate. This distance should not change as frame foot bolting is tightened.
7. Check total travel of impeller in casing. With new parts, acceptable range is 0.030 in. to 0.065 in. If outside this range, improper parts or installation or too much pipe strain is present. Determine cause and correct.
8. Adjust impeller clearance according to procedure outlined in the preventive maintenance section.
9. Replace auxiliary piping at this time.
10. Fill pump with proper lubricant. Refer to Preventive Maintenance fore requirements.

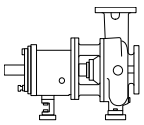

## Standard Bore Stuffing Box Dimensions For AMP OSG ANSI Process Pump

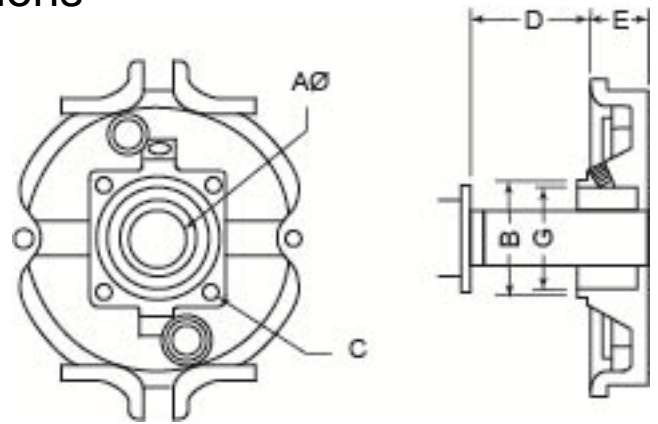

Standard Bore	A	B	C Drilled			D	E	G
			No.	Size	B.C.			
<b>STX</b>	1.375	2.394	4	0.375	3.250	2.188	2.125	2.125
<b>MTX</b>	1.750	3.000	4	0.500	4.125	2.813	2.625	2.625
<b>LTX</b>	2.125	3.375	4	0.625	RTF	2.813	2.625	3.000
<b>XLTX</b>	2.500	3.875	4	0.625	RTF	2.938	3.000	3.500

## Large Bore Stuffing Box Dimensions For AMP OSG ANSI Process Pump

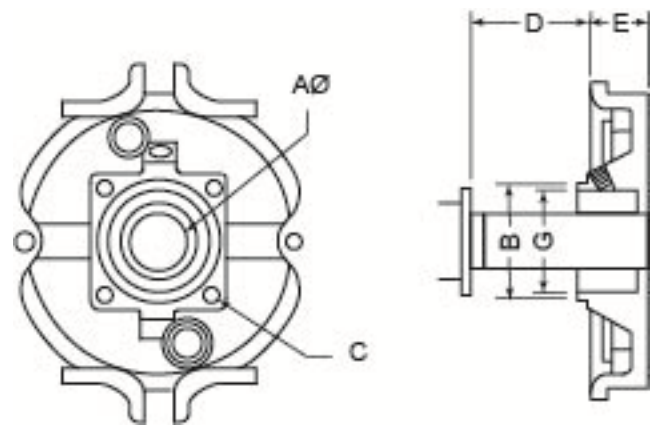

Large Bore	A	B	C Drilled			D	E	G
			No.	Size	B.C.			
<b>STX</b>	1.375	3.375	4	0.375	4.500	2.500	2.125	2.875
<b>MTX</b>	1.750	4.000	4	0.500	5.500	2.813	2.625	3.500
<b>LTX</b>	2.125	4.375	4	0.625	6.000	2.813	2.625	3.875
<b>XLTX</b>	2.500	5.460	4	0.625	6.750	2.850	3.000	4.750

FIGURE 14 – Seal Chamber Details

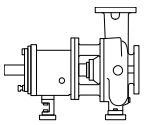

**BEARING MAINTENANCE**

**BEARING LUBRICATION**

**OIL BATH**

The standard bearing housing bearings are oil bath lubricated and are not lubricated by American-Marsh. Before operating the pump, fill the bearing housing to the center of the oil sight glass with the proper type oil. (See Figure 15 for approximate amount of oil required – do not overfill.) The oil level in the bearing housing must be maintained at ±1/8 in (±3 mm) from the center of the sight glass. The sight glass has a 1/4 in (6 mm) hole in the center of its reflector. The bearing housing oil level must be within the circumference of the center hole to ensure adequate lubrication of the bearings.

Pump	OSG Oil Capacity
STX	16 oz (400 ml)
MTX	42 oz (1250 ml)
LTX	48 oz (1400 ml)
XLTX	96 oz (3000 ml)

**FIGURE 15 – Amount of Oil Required**

Manufacturer	Oil	Grease
Exxon	Teresstic 68 or NUTO H68	Unirex N2
Mobil	Mobil DTE 26 300 SSU@100°F	Mobilux EP2
Sunoco	Sunvis 968	Multipurpose 2EP
Royal Purple	SYNFILM ISO VG 68 Synthetic Lube	NLGI #2

**FIGURE 16 – Recommended Lubricants**

Maximum Oil Temperature	ISO Viscosity Grade	Minimum Viscosity Index
Up to 160°F (71°C)	46	95
160-180°F (71°-82°C)	68	95
180-200°F (82°-94°C)	100	95

**FIGURE 17 – Oil Viscosity Grades**

See Figure 16 for recommended lubricants or equivalents. **DO NOT USE DETERGENT OILS.** The oil must be free of water, sediment, resin, soaps, acid and fillers of any kind. It should contain rust and oxidation inhibitors. The proper oil viscosity is determined by the bearing housing operating temperature as given in Figure 17. To add oil to the housing, clean and then remove the vent plug (#135) at the top of the bearing housing, pour in oil until it is visually half way up in the sight glass (#200). Fill the constant level oiler bottle (Trico), if used, and return it to its position. The correct oil level is obtained with the

constant level oiler in its lowest position, which results in the oil level being at the top of the oil inlet pipe nipple, or half way up in the sight glass window. Oil must be visible in the bottle at all times. As stated above, proper oil level is the center of the “bull’s eye” sight glass (#200).

Lubrication	Bearing Temperatures
Oil bath	120 to 180°F* (50 to 82°C)
Oil mist	120 to 180°F* (50 to 82°C)
Grease	Up to 230°F* (110°C)

**FIGURE 18 – Maximum External Housing Temperature**

In many pumping applications lubricating oil becomes contaminated before it loses its lubricating qualities or breaks down. For this reason it is recommended that the first oil change take place after approximately 160 hours of operation, at which time, the used oil should be examined carefully for contaminants. During the initial operating period monitor the bearing housing operating temperature. Record the external bearing housing temperature. See Figure 18 for maximum acceptable temperatures. The normal oil change interval is based on temperature and is shown in Figure 19.

Lubricant	Under 160°F (71°C)	160-175°F (71-80°C)	175-200°F (80-94°C)
Grease	3 mo	3 mo	1.5 mo
Mineral Oil	3 mo	3 mo	1.5 mo
Synthetic Oil**	6 mo	6 mo	3 mo

**FIGURE 19 – Re-lubrication Intervals**

**GREASE**

*Single shielded re-greasable bearings*

When the grease lubrication option is specified, single shielded bearings, grease fittings and vent pipe plugs are installed inboard and outboard. The bearings are packed with Royal Purple NLGI #2 grease prior to assembly. For initial lubrication, apply grease through the fittings until it comes out of the vent holes, then reinstall the pipe plugs. For re-lubrication, a grease with the same type base (non-soap polyuride) and oil (mineral) should be used. To re-grease, remove the pipe plug from both the inboard and outboard bearing location.

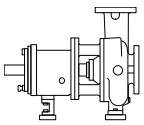

# ! WARNING

To re-grease bearings under coupling guard, stop pump, lock the motor, remove coupling guard, then re-grease the bearings.

Housing Location	Initial Lube	Re-lubrication
Group 1 Inboard	till grease comes out plug hole	6 g
Group 1 Outboard	till grease comes out plug hole	11 g
Group 1 Duplex	30 g	15 g
Group 2 Inboard	till grease comes out plug hole	15 g
Group 2 Outboard	till grease comes out plug hole	25 g
Group 2 Duplex	60 g	30 g
Group 3 Inboard	till grease comes out plug hole	26 g
Group 3 Outboard	till grease comes out plug hole	48 g
Group 3 Duplex	100 g	53 g

FIGURE 20 – Amount of Grease Required

Notes:

1. Royal Purple NLGI #2 grease density = 0.92 g/cm<sup>3</sup>.
2. Grams to ounces conversion: g \* 0.035 = oz.
3. Typical tube of grease holds 14 oz (397 g).
4. Grease reservoirs should be cleaned out every 18 months and new initial lube amount applied.

# ! CAUTION

Do not fill the housing with oil when greased bearings are used. The oil will leach the grease out of the bearings and the life of the bearings may be drastically reduced.

**Double shielded or double sealed bearings**  
These bearings are packed with grease by the bearing manufacturer and should not be re-lubricated. Maintenance intervals for these bearings are greatly affected by their operating temperature and pump speed. However, the shielded bearing typically operates cooler, thus extending its life.

## OIL MIST

When optional oil mist lubricated bearings are specified, the bearing housing is furnished with a plugged 1/2 in NPT top inlet for connection to the user's oil mist supply system, a vent fitting in the bearing carrier, and a plugged 1/4 in NPT bottom drain.

Do not allow oil level to remain above the center of the bearing housing sight glass window with purge mist (wet sump) systems.

## SPARE PARTS

### RECOMMENDED SPARE PARTS – STANDARD OSG PUMP

The decision on what spare parts to stock varies greatly depending on many factors such as the criticality of the application, the time required to buy and receive new spares, the erosive/corrosive nature of the application, and the cost of the spare part. Figures 21, 22, 23 & 24 give the parts list for a typical OSG pump. Please refer to the "American-Marsh Pump Parts Catalog" for more information. Prior to resizing impellers in high chrome iron and nickel, please consult your local American-Marsh sales representative.

### HOW TO ORDER SPARE PARTS

Spare parts can be ordered from the local American-Marsh Sales Engineer, or from the American-Marsh Distributor or Representative. The pump size and type can be found on the name plate on the bearing housing. See Figure 1. Please provide the item number, description, and alloy for the part(s) to be ordered.

To make parts ordering easy, American-Marsh has created a catalog titled "American-Marsh Pump Parts Catalog." A copy of this book can be obtained from the local American-Marsh Sales Engineer or Distributor/Representative.

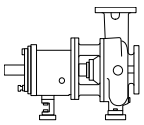

### FIGURE 21 –STX Sectional Drawing

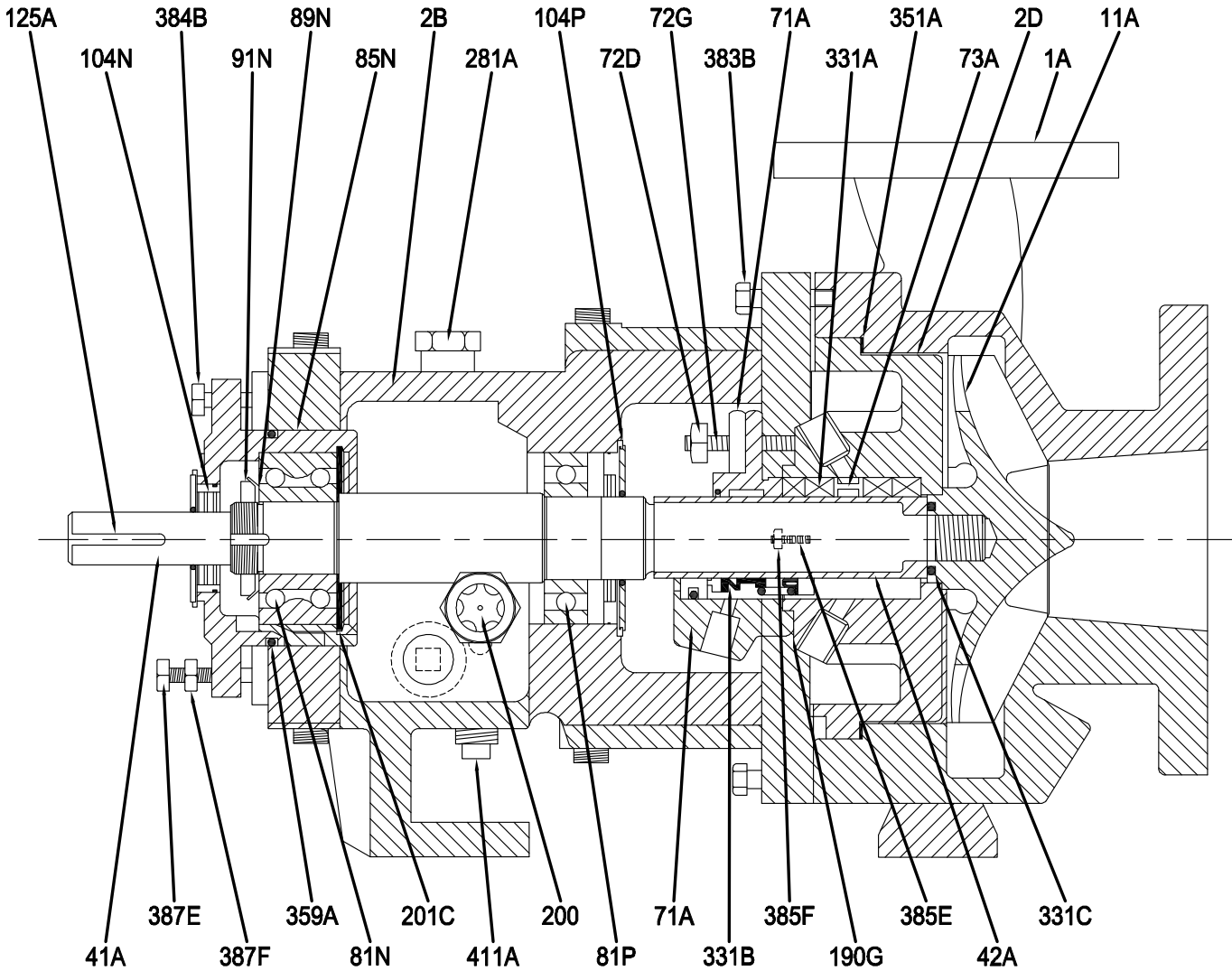

Item Number	Item Description	Num. Req.
1A	Casing	1
2B	Bearing Housing	1
2D	Rear Cover	1
11A	Impeller	1
41A	Shaft	1
42A	Shaft Hook Sleeve	1
71A	Stuffing Box Gland	1
72D	Gland Nut	4
72G	Gland Stud	4
73A	Lantern Ring	1
81N	Outboard Bearing, Thrust	1
81P	Inboard Bearing, Radial	1
85N	Bearing Carrier	1
89N	Outboard Bearing Lockwasher	1
91N	Outboard Bearing Locknut	1
104N	Outboard Lip Seal	1
104P	Inboard Lip Seal	1

Item Number	Item Description	Num. Req.
125A	Coupling Key	1
190G	Stuffing Box Gland Gasket	1
200	Sight Gauge	1
201C	Bearing Carrier Retainer	1
281A	Bearing Housing Vent Plug	1
331A	Packing	1 set
331B	Mechanical Seal	1
331C	Impeller O-Ring	1
351A	Casing Gasket	1
359A	Bearing Carrier O-Ring	1
383B	Casing Bolt	4
384B	Bearing Carrier Bolt	3
385B	Casing Jacking Bolt	2
385E	Rear Cover Stud	2
385F	Rear Cover Nut	2
387G	Bearing Housing Jam Nut	3
411B	Bearing Housing Drain Plug	1

**Recommended spare parts are in BOLD.**

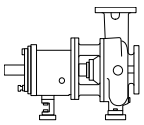

# FIGURE 22 – MTX Sectional Drawing

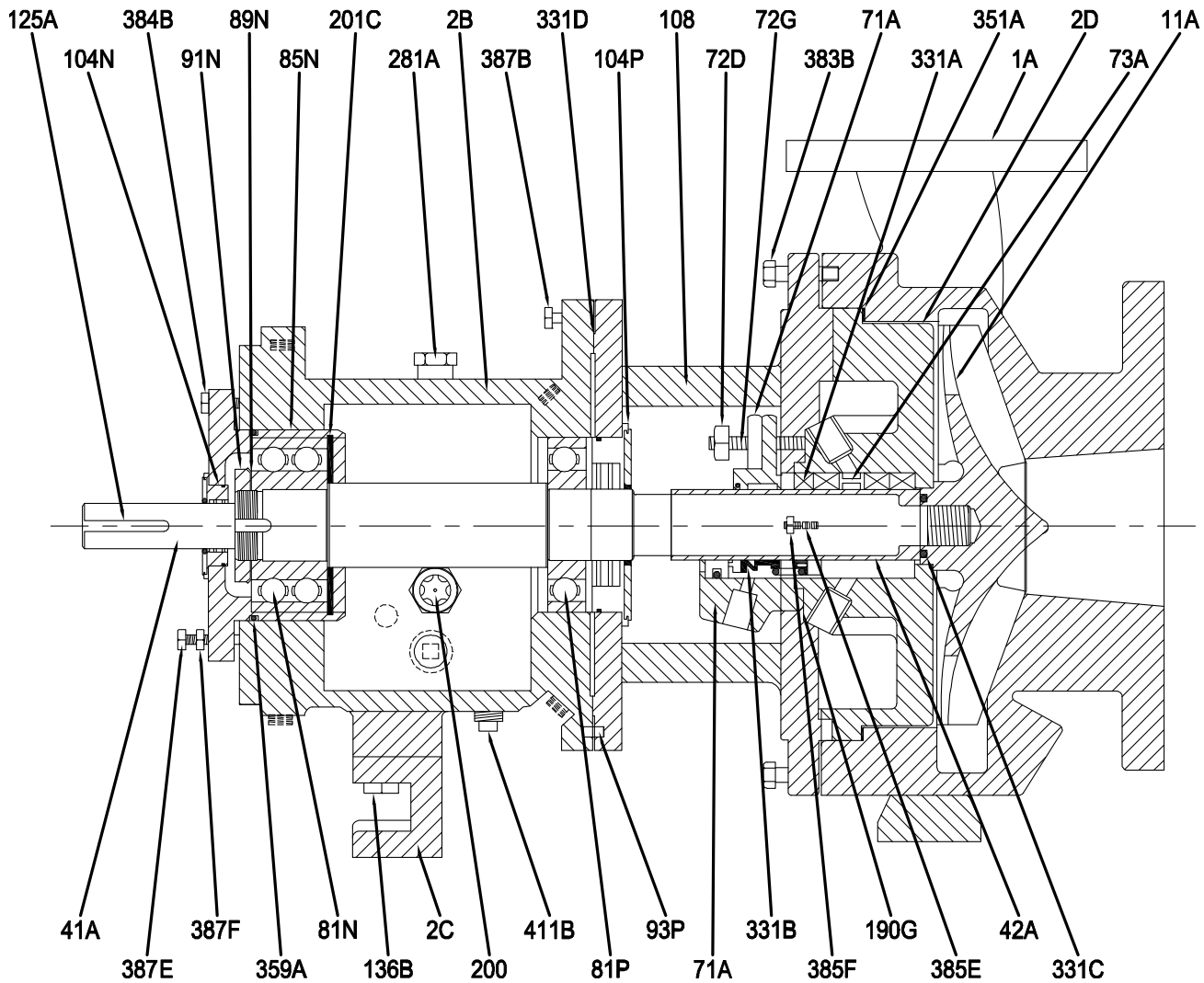

Item Number	Item Description	Num. Req.
1A	Casing	1
2B	Bearing Housing	1
2C	Bearing Housing Foot	1
2D	Rear Cover	1
<b>11A</b>	Impeller	1
41A	Shaft	1
<b>42A</b>	Shaft Hook Sleeve	1
71A	Stuffing Box Gland	1
72D	Gland Nut	4
72G	Gland Stud	4
<b>73A</b>	Lantern Ring	1
<b>81N</b>	Outboard Bearing, Thrust	1
<b>81P</b>	Inboard Bearing, Radial	1
85N	Bearing Carrier	1
89N	Outboard Bearing Lockwasher	1
91N	Outboard Bearing Locknut	1
93P	Bearing Housing Dowel Pin	2
<b>104N</b>	Outboard Lip Seal	1
<b>104P</b>	Inboard Lip Seal	1
108	Bearing Housing Adapter	1

Item Number	Item Description	Num. Req.
125A	Coupling Key	1
136B	Bearing Housing Foot Capscrew	2
<b>190G</b>	Stuffing Box Gland Gasket	1
200	Sight Gauge	1
201C	Bearing Carrier Retainer	1
281A	Bearing Housing Vent Plug	1
<b>331A</b>	Packing	1 set
<b>331B</b>	Mechanical Seal	1
<b>331C</b>	Impeller O-Ring	1
<b>331D</b>	Bearing Housing Gasket	1
<b>351A</b>	Casing Gasket	1
<b>359A</b>	Bearing Carrier O-Ring	1
383B	Casing Bolt	Various
384B	Bearing Carrier / Housing Bolt	3
385B	Casing Jacking Bolt	2
385E	Rear Cover Stud	2
385F	Rear Cover Nut	2
387B	Bearing Housing Stud	4
387E/F	Bearing Carrier Adjusting Stud/Nut	3
411B	Bearing Housing Drain Plug	1

**Recommended spare parts are in BOLD.**

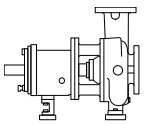

# FIGURE 23 – LTX Sectional Drawing

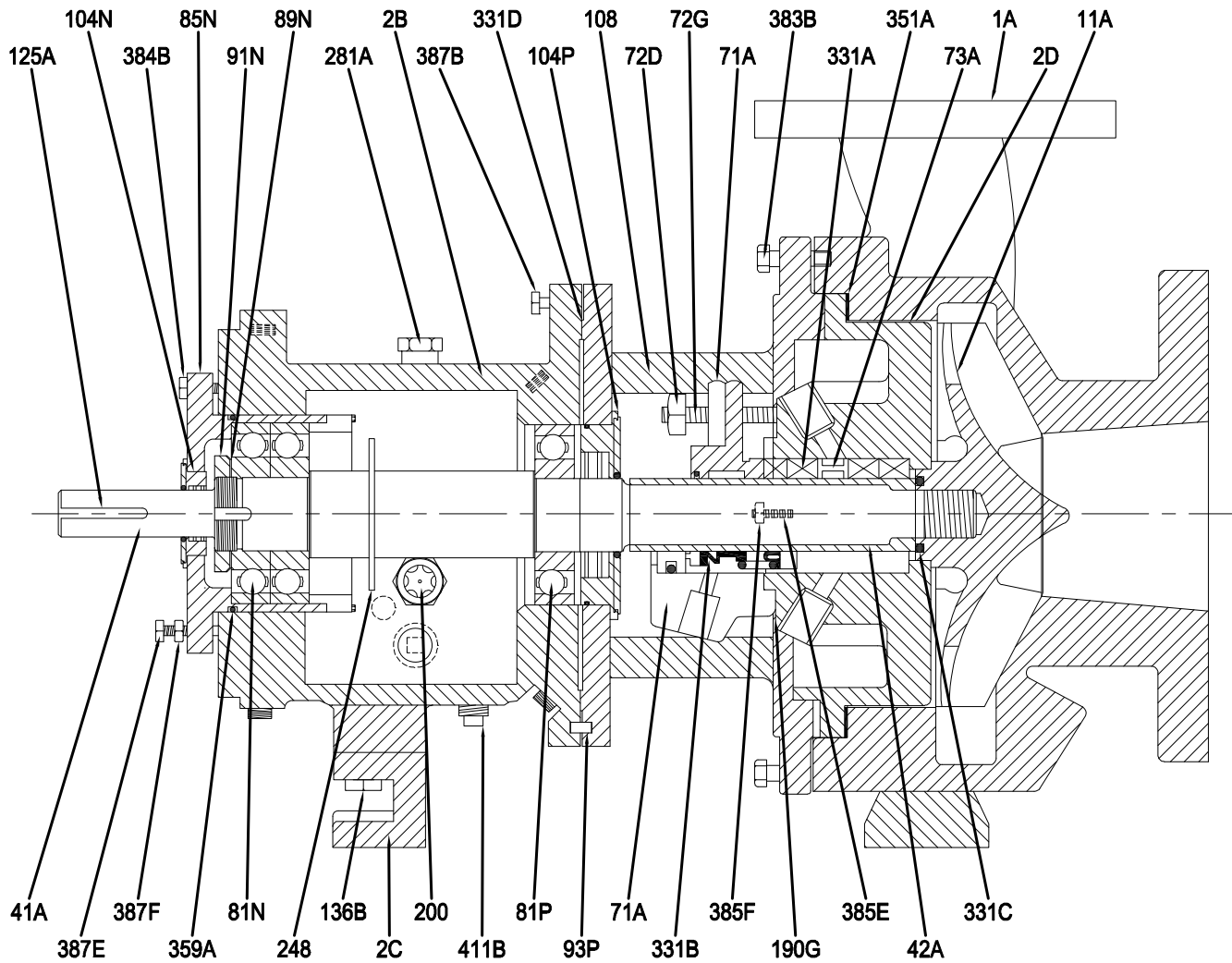

Item Number	Item Description	Num. Req.
1A	Casing	1
2B	Bearing Housing	1
2C	Bearing Housing Foot	1
2D	Rear Cover	1
<b>11A</b>	Impeller	1
41A	Shaft	1
<b>42A</b>	Shaft Hook Sleeve	1
71A	Stuffing Box Gland	1
72D	Gland Nut	4
72G	Gland Stud	4
73A	Lantern Ring	1
<b>81N</b>	Outboard Bearing, Thrust	1
<b>81P</b>	Inboard Bearing, Radial	1
85N	Bearing Carrier	1
89N	Outboard Bearing Lockwasher	1
91N	Outboard Bearing Locknut	1
93P	Bearing Housing Dowel Pin	2
<b>104N</b>	Outboard Lip Seal	1
<b>104P</b>	Inboard Lip Seal	1
108	Bearing Housing Adapter	1

Item Number	Item Description	Num. Req.
125A	Coupling Key	1
136B	Bearing Housing Foot Capscrew	2
<b>190G</b>	Stuffing Box Gland Gasket	1
200	Sight Gauge	1
201C	Bearing Carrier Retainer	1
248	Oil Thrower	1
281A	Bearing Housing Vent Plug	1
<b>331A</b>	Packing	1 set
<b>331B</b>	Mechanical Seal	1
<b>331C</b>	Impeller O-Ring	1
<b>331D</b>	Bearing Housing Gasket	1
<b>351A</b>	Casing Gasket	1
<b>359A</b>	Bearing Carrier O-Ring	1
383B	Casing Bolt	Various
384B	Bearing Carrier / Housing Bolt	3
385B	Casing Jacking Bolt	3
385E	Rear Cover Stud	2
385F	Rear Cover Nut	2
387E/F	Bearing Carrier Adjusting Stud/Nut	3
411B	Bearing Housing Drain Plug	1

**Recommended spare parts are in BOLD.**

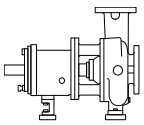

### FIGURE 24 – XLTX Sectional Drawing

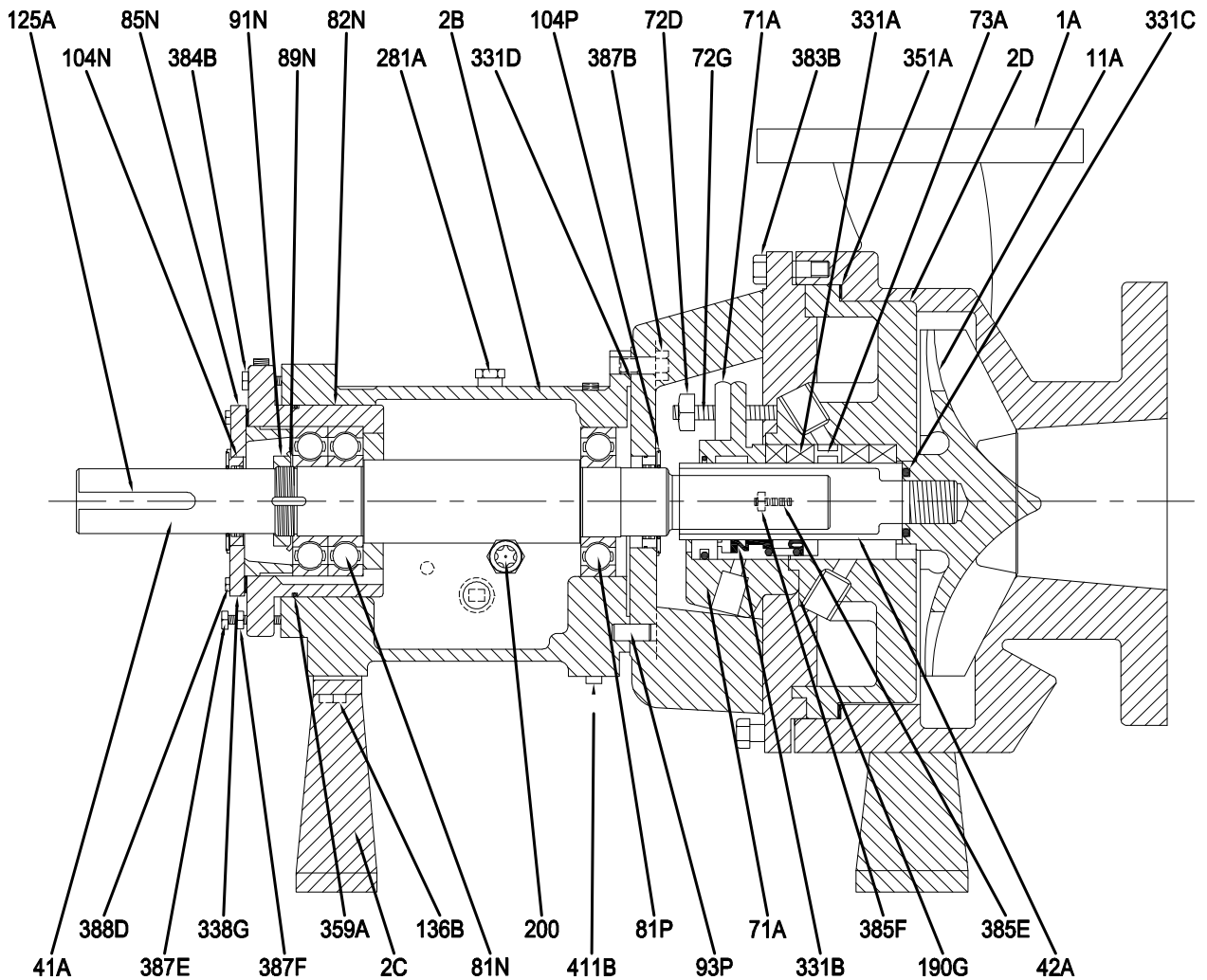

Item Number	Item Description	Num. Req.
1A	Casing	1
2B	Bearing Housing	1
2C	Bearing Housing Foot	1
2D	Rear Cover	1
<b>11A</b>	<b>Impeller</b>	1
41A	Shaft	1
42A	Shaft Hook Sleeve	1
71A	Stuffing Box Gland	1
72D	Gland Nut	4
72G	Gland Stud	4
73A	Lantern Ring	1
81N	Outboard Bearing, Thrust	1
81P	Inboard Bearing, Radial	1
82N	Bearing Carrier	1
85N	Bearing End Cover	1
89N	Outboard Bearing Lockwasher	1
91N	Outboard Bearing Locknut	1
93P	Bearing Housing Dowel Pin	2
<b>104N</b>	<b>Outboard Lip Seal</b>	1
<b>104P</b>	<b>Inboard Lip Seal</b>	1
108	Bearing Housing Adapter	1

Item Number	Item Description	Num. Req.
125A	Coupling Key	1
136B	Bearing Housing Foot Capscrew	2
<b>190G</b>	<b>Stuffing Box Gland Gasket</b>	1
200	Sight Gauge	1
201C	Bearing Carrier Retainer	1
281A	Bearing Housing Vent Plug	1
<b>331A</b>	<b>Packing</b>	1 set
<b>331B</b>	<b>Mechanical Seal</b>	1
<b>331C</b>	<b>Impeller O-Ring</b>	1
<b>331D</b>	<b>Bearing Housing Gasket</b>	1
<b>351A</b>	<b>Casing Gasket</b>	1
<b>359A</b>	<b>Bearing Carrier O-Ring</b>	1
383B	Casing Bolt	Various
384B	Bearing Carrier / Housing Bolt	4
385B	Casing Jacking Bolt	3
385E	Rear Cover Stud	2
385F	Rear Cover Nut	2
387E/F	Bearing Carrier Adjusting Stud/Nut	4
388D	Bearing End Cover Capscrew	6
411B	Bearing Housing Drain Plug	1

**Recommended spare parts are in BOLD.**

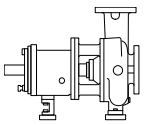

## APPENDIX A

### CRITICAL MEASUREMENTS AND TOLERANCES FOR MAXIMIZING MTBPM

#### PARAMETERS THAT SHOULD BE CHECKED BY USERS

American-Marsh recommends that the user check the following measurements and tolerances whenever pump maintenance is performed. Each of these measurements is described in more detail on the following pages.

Topic	ASME B73.1M Std. in (mm)	Suggested By Major Seal Vendors in (mm)	Suggested And/Or Provided By AMP in (mm)
Shaft			
Diameter tolerance, under bearings	N.S.		0.0002 (0.005)
Impeller			
Balance			See Note 1
Bearing Housing			
Diameter (ID) tolerance at bearings	N.S.		0.0005 (0.013)
Power End Assembly			
Shaft Runout	0.002 (0.05)	0.001 (0.03)	0.001 (0.03)
Shaft Sleeve Runout	0.002 (0.05)	0.002 (0.05)	0.002 (0.05)
Radial Deflection - Static	N.S.	0.003 (0.076)	0.002 (0.05)
Shaft Endplay	N.S.	0.002 (0.05)	0.002 (0.05)
Seal Chamber			
Face Squareness to Shaft	0.003 (0.08)	0.001 (0.03)	0.003 (0.08)
Register Concentricity	0.005 (0.13)	0.005 (0.13)	0.005 (0.13)
Complete Pump			
Shaft movement caused by pipe strain	N.S.	0.002 (0.05)	0.002 (0.05)
Alignment	N.S.		See Note 2
Vibration at bearing housing	0.25 in/s (6.3 mm/s)		See Note 3

**FIGURE 25 - Measurements**

N.S. = Not specified

**Note 1:** The maximum values of acceptable unbalance are: 1800 rpm: 0.021 oz•in/lb (1500 rpm: 40 g•mm/kg) of mass; 3600 rpm: 0.011 oz•in/lb (2900 rpm: 20 g•mm/kg) of mass. American-Marsh performs a single plane spin balance on most impellers. The following impellers are exceptions: 8x10-14 and 8x10-16H. On these American-Marsh performs a two plane dynamic balance, as required by the ASME B73.1M standard. All balancing, whether single or two plane, is performed to the ISO 1940 Grade 6.3 tolerance criteria.

**Note 2:** The ASME B73.1M standard does not specify a recommended level of alignment. American-Marsh recommends that the pump and motor shafts be aligned to within 0.002 in (0.05 mm) parallel F.I.M. (Full Indicator Movement) and 0.0005 in/in (0.0005 mm/mm) angular

F.I.M. Closer alignment will extend MTBPM. For a detailed discussion of this subject see the Alignment section of this IOM.

**Note 3:** The ASME B73.1M standard for vibration at the bearing housing is 0.25 in/s (6.3 mm/second) peak velocity or 0.0025 (63 μm) peak-to-peak displacement. American-Marsh recommends the following peak velocities, in in/s (mm/second): Group 1 = 0.1 (2.5), Group 2 = 0.15 (3.8), Group 3 = 0.25 (6.3).

#### ADDITIONAL PARAMETERS CHECKS BY AMERICAN-MARSH

The parameters listed below are somewhat more difficult to measure and/or may require specialized equipment. For this reason, they are not typically checked by our customers, although they are monitored by American-Marsh during the manufacturing and/or design process. These parameters are described at the end of this appendix.

Topic	ASME B73.1M Std.	Suggested By Major Seal Vendors	Suggested And/Or Provided By AMP
Shaft - Maximum roughness at seal chamber	32μin (0.80 μm)		16μin (0.40 μm)
Bearing Housing - Bore Concentricity			0.001 in (0.025 mm)
Complete Pump – Dynamic Shaft Deflection*	0.005 in (0.13 mm)	0.002 in (0.05 mm)	0.002 in (0.05 mm)

**FIGURE 26 – Specialized Measurements**

\*The ASME standard recommends 0.005 in (0.13 mm) max deflection at the impeller, while American-Marsh provides 0.002 in (0.05 mm) max deflection at the mechanical seal. The two recommendations are essentially equivalent.

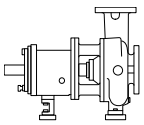

## SHAFT

Before installing the shaft into the power end it is important to check the following parameters.

### Diameter tolerance, under bearings

In order to ensure that the bearings fit around the shaft properly, it is important that the shaft diameter is consistently within the min/max values given below. A micrometer should be used to check the dimension of the OD of the shaft.

		STX	MTX	LTX
OB brg ID to shaft OD	Bearing to Shaft Fit	1.1811/1.1815 1.1807/1.1812 0.008T/0.0001T	1.7717/1.7722 1.7712/1.7718 0.0010T/0.0001T	1.9685/1.9690 1.9680/1.9686 0.0010T/0.0001T
IB brg ID to shaft OD	Bearing to Shaft Fit	1.3780/1.3785 1.3775/1.3781 0.0010T/0.0001T	1.7717/1.7722 1.7712/1.7718 0.0010T/0.0001T	2.1654/2.1660 2.1648/2.1655 0.0012T/0.0001T

**FIGURE 27 – Bearing/Shaft Dimensions**

The ID of the bearings should also be checked and should conform to the min/max values given above.

## IMPELLER BALANCING

Shaft whip is deflection where the centerline of the impeller is moving around the true axis of the pump. It is not caused by hydraulic force but rather by an imbalance with the rotating element. Shaft whip is very hard on the mechanical seal because the faces must flex with each revolution in order to maintain contact. To minimize shaft whip it is imperative that the impeller is balanced. All impellers manufactured by American-Marsh are balanced after they are trimmed. If for any reason, a customer trims an impeller, it must be re-balanced.

The maximum values of acceptable unbalance are:  
 1800 rpm: 0.021 oz•in/lb (1500 rpm: 40 g•mm/kg) of mass  
 3600 rpm: 0.011 oz•in/lb (2900 rpm: 20 g•mm/kg) of mass

American-Marsh performs a single plane spin balance on most impellers. All balancing, whether single or two plane, is performed to the ISO 1940 Grade 6.3 tolerance criteria.

## BEARING HOUSING

### Diameter (ID) tolerance at bearings

An inside caliper should be used to check the dimension of the ID of the housing and bearing carrier. The diameter must be within the following min/max values given in order to provide the proper bearing tightness.

The OD of the bearings should also be checked and should conform to the min/max values given above.

## POWER FRAME ASSEMBLY

### Shaft/Shaft Sleeve Runout

Shaft runout is the amount the shaft is “out of true” when rotated in the pump. It is measured by attaching a dial indicator to a stationary part of the pump so that its contact point indicates the radial movement of the shaft surface as the shaft is rotated slowly. If a shaft sleeve is used then shaft sleeve runout must be checked. It is analogous to shaft runout.

Measurement of shaft runout/ shaft sleeve runout will disclose any out of roundness of the shaft, any eccentricity between the shaft and the sleeve, any permanent bend in the shaft, and/or any eccentricity in the way the shaft or bearings are mounted in the bearing housing.

Shaft runout can shorten the life of the bearings and the mechanical seal. The following diagram shows how to measure shaft/ shaft sleeve runout. Note that both ends need to be checked. The runout should be 0.001 in (0.025 mm) FIM or less.

R.P.M.	MODEL			
	STX	MTX	LTX	XLTX
<b>3560</b>	40.0	122.0	200.0	N/R
<b>2900</b>	32.7	99.5	165.0	N/R
<b>1780</b>	20.0	61.0	100.0	249.0
<b>1450</b>	16.3	49.7	81.5	203.0
<b>1180</b>	13.3	40.5	66.4	165.0
<b>880</b>	9.9	30.2	49.5	123.0

**FIGURE 28 – Brake Horsepower Limits**

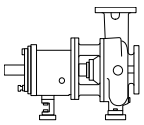

		STX	MTX	LTX
OB brg OD to hsg ID	Bearing	2.8346/2.8346	3.9370/3.9370	4.3307/4.3307
	Housing	2.8341/2.8353	3.9364/3.9379	4.3301/4.3316
	Fit	0.0012L/0.0000L	0.0015L/0.0000L	0.0015L/0.0000L
IB brg OD to hsg ID	Bearing	2.8346/2.8346	3.9370/3.9370	4.7244/4.7244
	Housing	2.8341/2.8353	3.9364/3.9379	4.7238/4.7253
	Fit	0.0012L/0.0000L	0.0015L/0.0000L	0.0015L/0.0000L

**FIGURE 29 – Bearing Housing Tolerances**

**Radial Deflection – Static**

Radial movement of the shaft can be caused by a loose fit between the shaft and the bearing and/or the bearing and the housing. This movement is measured by attempting to displace the shaft vertically by applying an upward force of approximately ten pounds to the impeller end of the shaft. While applying this force, the movement of an indicator is observed as shown in the following diagram. The movement should be checked at a point as near as possible to the location of the seal faces. A movement of more than 0.002 in (0.05 mm) is not acceptable.

**Shaft Endplay**

The maximum amount of axial shaft movement, or endplay, on an American-Marsh pump should be 0.001 in (0.03 mm) and is measured as shown below. Observe indicator movement while tapping the shaft from each end in turn with a soft mallet. Shaft endplay can cause several problems. It can cause fretting or wear at the point of contact between the shaft and the secondary sealing element. It can also cause seal overloading or underloading and possibly chipping of the seal faces. It can also cause the faces to separate if significant axial vibration occurs.

**SEAL CHAMBER**

**Face Squareness to Shaft**

Also referred to as “Seal Chamber Face Run-Out.” This runout occurs when the seal chamber face is not perpendicular to the shaft axis. This will cause the gland to cock, which causes the stationary seat to be cocked, which causes the seal to wobble. This runout should be less than 0.003 in (0.08 mm) and should be measured as shown below:

**Register Concentricity**

An eccentric seal chamber bore or gland register can interfere with the piloting and centering of the seal components and alter the hydraulic loading of the seal faces, resulting in reduction of seal life and performance. The seal chamber register concentricity should be less than 0.005 in (0.13 mm). The diagram below shows how to measure this concentricity.

**COMPLETE PUMP**

**Shaft Movement Caused by Pipe Strain**

Pipe strain is any force put on the pump casing by the piping. Pipe strain should be measured as shown below. Install the indicators as shown before attaching the piping to the pump. The suction and discharge flanges should now be bolted to the piping separately while continuously observing the indicators. Indicator movement should not exceed 0.002 in (0.05 mm).

**Alignment**

Misalignment of the pump and motor shafts can cause the following problems:

- Failure of the mechanical seal
- Failure of the motor and/or pump bearings
- Failure of the coupling
- Excessive vibration/noise

The schematics below show the technique for a typical rim and face alignment using a dial indicator. It is important that this alignment be done after the flanges are loaded, and at typical operating temperatures. If proper alignment cannot be maintained a C-flange motor adapter and/or stilt/spring mounting should be considered.

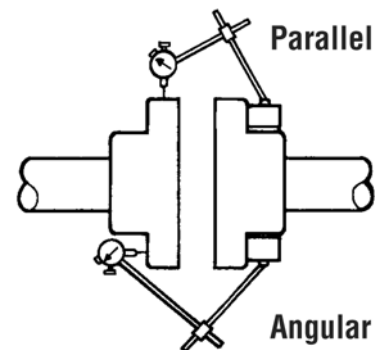
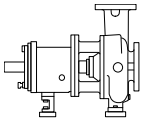

**FIGURE 30 – Alignment**

Many companies today are using laser alignment which is a more sophisticated and accurate technique. With this method a laser and sensor measure misalignment. This is fed to a computer with a graphic display which shows the required adjustment for each of the motor feet.

**Vibration Analysis**

Vibration Analysis is a type of condition monitoring where a pump’s vibration “signature” is monitored on a regular, periodic basis. The primary goal of vibration analysis is extension on MTBPM. By using this tool American-Marsh can often determine not only the existence of a problem before it becomes serious, but also the root cause and possible the solution. Modern vibration analysis equipment not only detects if a vibration problem exists, but can also suggest the cause of the problem. On a centrifugal pump, these causes



can include the following: unbalance, misalignment, defective bearings, resonance, hydraulic forces, cavitation, and recirculation. Once identified, the problem can be corrected, leading to increased MTBPM for the pump.

American-Marsh does not make vibration analysis equipment, however American-Marsh strongly urges customers to work with an equipment supplier or consultant to establish an on-going vibration analysis program. The ASME standard for vibration at the bearing housing is 0.25 inches/second (6.35 mm/sec) peak velocity or 0.0025 inches (0.064 mm) peak-to-peak displacement.

### ***SPECIAL PARAMETERS CHECKED BY AMERICAN-MASH***

#### **SHAFT – MAXIMUM ROUGHNESS AT SEAL CHAMBER**

The ASME B73.1M standard requires that the surface finish of the shaft (or sleeve) through the stuffing box and at rubbing contact bearing housing seals shall not exceed a roughness of 32  $\mu\text{in}$  (0.8  $\mu\text{m}$ ). American-Marsh shafts do not exceed 16  $\mu\text{in}$  (0.4  $\mu\text{m}$ ) at these areas. American-Marsh audits smoothness by using a profilometer surface finish gauge.

#### **BEARING HOUSING – BORE CONCENTRICITY**

If the bore for holding the bearing is eccentric, the bearing will be shifted off center. This will contribute to shaft runout. American-Marsh measures this concentricity by using computerized measuring equipment. The concentricity should not exceed 0.001 in (0.03 mm).

#### **COMPLETE PUMP – DYNAMIC SHAFT DEFLECTION**

In regards to pump operation, a very important factor for maximizing pump MTBPM is the avoidance of off-design pump operation. In order to maximize the life of the seal and bearings, a process pump should be run as close as possible to its Best Efficiency Point (BEP).

Dynamic shaft deflection is a deflection of the shaft caused by unbalanced hydraulic forces acting on the impeller. Dynamic shaft deflection will change as the pump is operated on various points along the curve. When the pump is operated at BEP, the shaft deflection is zero. This deflection is very difficult to measure. The ASME B73.1M standard states that dynamic shaft deflection at the impeller centerline shall not exceed 0.005 in (0.13 mm) at maximum load (shutoff) for pump sizes A70 and smaller and at design load for pump sizes A80 and larger.

At a given point on the curve, the shaft deflection is constant and is constantly in the same direction. The centerline of the impeller, though bent from parallel, does not move. For this reason, in many cases, shaft deflection is not particularly hard on mechanical seals. It is, however, hard on bearings, since the force which causes shaft deflection can be a tremendous load on them. The amount of deflection depends on three factors: how the shaft is supported, the strength of the shaft and the amount of unbalanced hydraulic force experienced by the shaft/impeller. If there seems to be a shaft deflection problem, refer to the American-Marsh Pump Engineering Manual for a detailed discussion on how to calculate deflection.

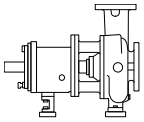

## APPENDIX B

### IMPELLER CLEARANCE SETTING

The impeller clearance setting procedure must be followed. Improperly setting the clearance or not following any of the proper procedures can result in sparks, unexpected heat generation and equipment damage.

# ! WARNING

*The impeller could have sharp edges which could cause an injury. It is very important to wear heavy gloves. Lock out driver power to prevent accidental startup and physical injury.*

# ! CAUTION

*Do not attempt to tighten the impeller on the shaft by hitting the impeller with a hammer or any other object or by inserting a pry bar between the impeller vanes. Serious damage to the impeller may result from such actions.*

A change in pump performance may be noted over time by a drop in head or flow or an increase in power required. Performance can usually be renewed by adjusting the impeller clearance. Two techniques are given to set the impeller clearance, the dial indicator method and the feeler gauge method.

#### DIAL INDICATOR METHOD

1. Remove coupling guard.
2. Remove coupling.

3. Set indicator so that button contracts either the shaft end or against face of coupling.
4. Loosen jam nuts (#387G) on jack bolts (#387B) and back bolts out about two turns.
5. Tighten each locking bolt (#384B) evenly, drawing the bearing housing (85N) towards the bearing frame (#2B) until impeller contacts the casing. Turn the shaft to ensure contact is made.
6. Set indicator to zero and back locking bolt (#384B) out about one turn.
7. Thread jack bolts (#387B) in until they evenly contact the bearing frame. Tighten the jack bolts evenly (about one flat at a time) backing the bearing housing (#85N) away from the bearing frame until the indicator shows the proper clearance per Figure 8.
8. Evenly tighten locking bolts (#384B), then jack bolts (#387B) keeping indicator reading at proper setting.
9. Check shaft for free turning.
10. Replace coupling and coupling guard.

#### FEELER GAUGE METHOD

1. Remove coupling guard.
2. Loosen jam nuts (#387G) on jack bolts (#387B) and back bolts out about two turns.
3. Tighten each locking bolt (#384B) evenly, drawing the bearing housing (#85N) towards the bearing frame (#2B) until impeller contacts the casing. Turn the shaft to ensure contact is made.
4. Using feeler gauge, set the gap between the three locking bolts (#384B) and bearing housing (#85N) per impeller clearances in Figure 8.
5. Evenly back out bearing housing (#85N) using the three jack bolts (#387B) until it contacts the locking bolts (#384B). Evenly tighten jam nuts (#387G).
6. Check shaft for free turning.
7. Replace coupling and coupling guard.

Temperature – °F (°C)	Clearance to cover – in (mm)		
	STX	MTX/LTX	XLTX
-20 to 200 (-29 to 93)	0.005 (0.13)	0.005 (0.13)	0.005 (0.13)
200 to 250 (93 to 121)	0.006 (0.16)	0.006 (0.16)	0.006 (0.16)
251 to 300 (122 to 149)	0.007 (0.19)	0.007 (0.19)	0.007 (0.19)
301 to 350 (150 to 176)	0.009 (0.22)	0.009 (0.22)	0.009 (0.22)
351 to 400 (177 to 204)	0.010 (0.25)	0.010 (0.25)	0.010 (0.25)
401 to 450 (205 to 232)	0.011 (0.28)	0.011 (0.28)	0.011 (0.28)
451 to 500 (233 to 260)	0.012 (0.30)	0.012 (0.30)	0.012 (0.30)

**FIGURE 31 – Impeller Clearance Settings**

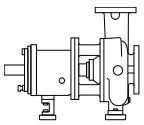

## APPENDIX C

### AMERICAN-MARSH OSG MAINTENANCE INSTRUCTIONS BEARING HOUSING OIL SEALS (LABYRINTH TYPE) INPRO/SEAL® VBXX BEARING ISOLATORS

#### INTRODUCTION

American-Marsh Pumps provides pumps fitted with a variety of labyrinth oil seals. While these instructions are written specifically for the Inpro/Seal VBXX labyrinth, they also apply to seals of other manufacturers. Specific installation instructions included with the seal, regardless of manufacturer, should be observed.

The Inpro “VBXX” Bearing Isolator is a labyrinth type seal which isolates the bearings from the environment (uncontaminated), and retains the oil in the bearing housing. The bearing isolator consists of a rotor and a stator. The rotor revolves with the shaft, driven by a close fitted drive ring that rotates with the shaft. The stator is a stationary component that fits into the housing bore with a press fit (nominal 0.002 in (0.05 mm) interference) and with an “O” ring gasket seal. The two pieces are assembled as a single unit, and are axially locked together by an “O” ring. There is no mechanical contact between the rotor and stator when the isolator is running.

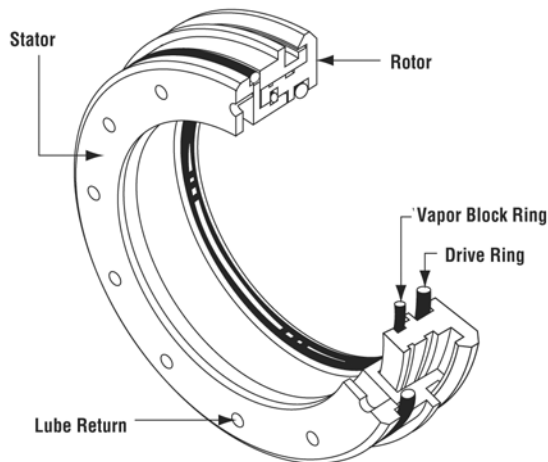

FIGURE 32 – Bearing Isolator

The VBXX is not intended to be separated from the bearing housing/adaptor/carrier unless being replaced.

1. If the VBXX is removed from the housing, for any reason, it must be replaced with a new VBXX to ensure a perfect seal with the housing bore.
2. Repair or replacement of the seals is only necessary when excessive oil leakage is evident. However, if for any other reason, the

bearing housing is to be disassembled or the pump shaft removed, it is recommended that the rotor “O” rings (which seal on the shaft) be replaced. Spare or replacement “O” rings may be obtained from “Inpro” distributors.

The “Inpro” VBXX bearing isolator is a one piece assembly. The rotor must not pull out of the stator. If the rotor can be removed, the complete seal assembly must be replaced.

3. If the bearing housing or bearing carrier with bronze VBXX seals is washed or cleaned using a caustic type bath, the bronze material may discolor (turn black). If this happens, the complete seal assembly must be replaced.
 

**Note:** This may occur if the housing is left in a caustic bath over a long period of time (more than 8 hours).
4. To remove the VBXX bearing isolator:
  - A. Remove the pump shaft as described in the pump disassembly instructions.
  - B. From the inside of the bearing housing or bearing carrier, place a bar (made from a soft material such as wood or plastic) against the inside face of the seal. Push the seal out by tapping the bar with a soft mallet or an arbor press.
5. To install a new VBXX bearing isolator, in the impeller end of the bearing housing/adaptor:
  - A. Position the impeller end (inboard) seal in the bore of the adapter or bearing housing with the **single expulsion port at the 6 o'clock position**, (carefully keep aligned with the bore).
  - B. The seal stator O.D. press fits into the bore. Use an arbor press. Place a block or bar (large enough to protect the rotor flange) between the arbor press ram and seal face. Press the seal down into the bore stopping at the shoulder on the stator O.D.

The elastomer “O” ring acts as a gasket to ensure damming up of small imperfections in the housing bore. The “O” ring is designed to be compressed to the point of overfilling its groove. The overfilled material is sheared off during assembly. Remove any sheared “O” ring material which may extrude from the bore.
6. To install a new VBXX bearing isolator in the drive end (outboard) side of the bearing carrier:
  - A. Position the outboard seal in the bore of the bearing carrier (no orientation of the multiple expulsion ports is necessary) and carefully keep aligned with the bore.

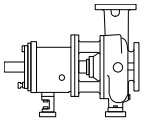

If the outboard seal has only one explosion port, that port must be oriented at the 6 o'clock position. Because the bearing carrier rotates for impeller adjustment, take the necessary steps to ensure the explosion port is oriented at 6 o'clock when the pump is installed and operating.

B. The seal stator O.D. press fits into the bore. Use an arbor press. Place a block or bar (large enough to protect the rotor flange) between the arbor press ram and seal face. Press the seal down into the bore stopping at the shoulder on the stator O.D. Remove any sheared o-ring material which may extrude from the bore.

7. Assemble the bearing carrier/VBXX bearing isolator on to the shaft:
  - A. The outboard double row bearing is nested inside of the bearing carrier, and retained in place by a snap ring. This **snap ring has a tapered edge on one side. The snap ring must be installed with the flat face of the snap ring against the bearing** and the tapered edge away from the bearing.
  - B. Using sand paper, remove burrs and break any sharp edges off the keyway at end of the shaft.
  - C. It is important to prevent the corners of the keyway from cutting the "O" rings during assembly. This can be accomplished with the use of a half key or a thin flexible sleeve. Lightly lubricate the shaft and slide the bearing carrier on to the shaft, pushing on the VBXX rotor, until the bearing is seated. Assemble the bearing retainer snap ring.
  - D. Check the position of the rotor (make sure rotor and stator have not separated) and seat the rotor snugly into the stator by hand.
8. Assemble the shaft/bearings into the bearing housing:
  - A. **Screw a tapered cone into the impeller end of the shaft to act as a guide and to prevent from cutting the rotor "O" ring.**
  - B. Lightly lubricate the shaft and assemble the shaft into the bearing housing, sliding the shaft through the rotor, keeping the rotor seated snugly into the stator by hand.

- C. After the bearing carrier is screwed in place, rotate the shaft and check to make sure that both seal rotors are positioned snugly inside of the stators. If for some reason, the rotor becomes disengaged or is pushed completely out of the stator, the VBXX bearing isolator must be replaced. It is not advisable to force the rotor back into the stator.

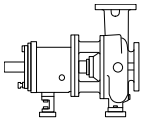

**APPENDIX D**

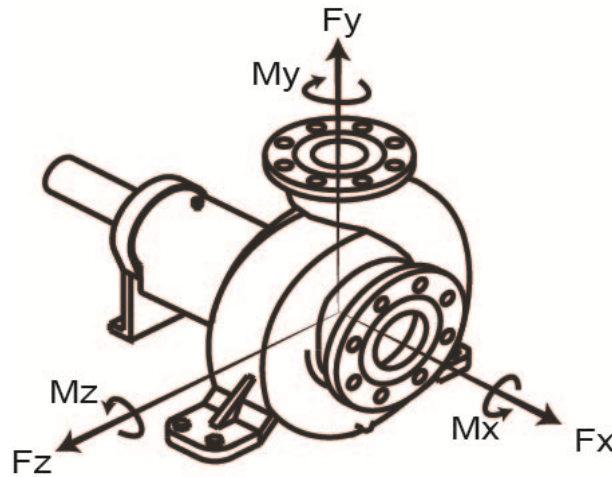

**FIGURE 33 – Forces & Moments**  
**ALLOWABLE NOZZLE LOADS OSG PUMPS (ASME B73.1M)**

The allowable nozzle loads listed in Figure 32 may be applied to any OSG Standard Horizontal and Lo-Flo pumps in Ductile cast iron, Carbon Steel, 316 Stainless Steel, Cd4MCu, Monel, and Inconel. The allowable loads must be multiplied by 0.70 for pumps made of nickel, titanium, zirconium and high chrome iron.

The loads listed in Figure 33 and 34 are the combined values resolved to the center of the pump, except for the  $F_r + M_r/3$  limits, which apply to the separate suction and discharge flanges. Some piping analysis programs calculate forces and moments on each flange, and do not translate them to a common point at the center of the pump. The formulas in Figure 35 and Dimensions in Figure 36 can be used to translate the forces and moments on each flange to the common center point.

Pump Nozzle Sizes	Combined Loading at Center of Pump						Flange Suction $F_{rs} + M_{rs}/3$	Loading Discharge $F_{rd} + M_{rd}/3$
	Forces (lbf)			Moments (lbf·ft)				
	$F_x$	$F_y$	$F_z$	$M_x$	$M_y$	$M_z$		
1 x 1.5	120	295	235	590	295	295	325	220
1.5 x 1.5	120	295	235	590	295	295	325	325
1 x 2	145	365	285	730	365	365	435	220
1.5 x 2	165	405	325	815	405	405	435	325
2 x 2	175	435	350	875	435	435	435	435
1.5 x 3	220	545	435	1090	545	545	650	325
2 x 3	235	590	470	1170	590	590	650	435
3 x 3	260	650	520	1300	650	650	650	650
3 x 4	325	815	650	1625	815	815	865	650
4 x 6	470	1170	940	2345	1170	1170	1300	865
6 x 8	610	1520	1215	3030	1520	1520	1730	1300
8 x 10	670	1670	1335	3350	1670	1670	1870	1730

**FIGURE 34 – Forces & Moments (US Units)**

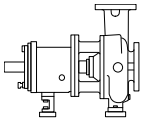

Pump Nozzle Sizes	Combined Loading at Center of Pump						Flange Suction Frs+Mrs*1.09	Loading Discharge Frd+Mrd*1.03
	Forces (N)			Moments (N•m)				
	Fx	Fy	Fz	Mx	My	Mz		
1 x 1.5	534	1313	1046	802	401	401	1446	979
1.5 x 1.5	534	1313	1046	802	401	401	1446	1446
1 x 2	645	1624	1268	993	496	496	1936	979
1.5 x 2	734	1802	1446	1108	551	551	1936	1446
2 x 2	779	1936	1558	1190	592	592	1936	1936
1.5 x 3	979	2425	1936	1482	741	741	2893	1446
2 x 3	1046	2626	2092	1591	802	802	2893	1936
3 x 3	1157	2893	2314	1768	884	884	2893	2893
3 x 4	1446	3627	2893	2210	1108	1108	3849	2893
4 x 6	2093	5207	4183	3189	1591	1591	5785	3849
6 x 8	2715	6764	5407	4121	2067	2067	7699	5785
8 x 10	2982	7432	5941	4556	2271	2271	8322	7699

**FIGURE 35 – Forces & Moments (Metric Units)**

Formula for all pumps
$F_x = F_{xs} + F_{xd}$
$F_y = F_{ys} + F_{yd}$
$F_z = F_{zs} + F_{zd}$
$M_x = M_{xs} + M_{xd} + (F_{zd} \cdot H) + (F_{zs} \cdot M)$
$M_y = M_{ys} + M_{yd} + (-F_{zs} \cdot L)$
$M_z = M_{zs} + M_{zd} + (F_{ys} \cdot L) - (F_{xd} \cdot H) - (F_{xs} \cdot M)$
$F_{rs} = \sqrt{(F_{xs}^2 + F_{ys}^2 + F_{zs}^2)}$
$M_{rs} = \sqrt{(M_{xs}^2 + M_{ys}^2 + M_{zs}^2)}$
$F_{rd} = \sqrt{(F_{xd}^2 + F_{yd}^2 + F_{zd}^2)}$
$M_{rd} = \sqrt{(M_{xd}^2 + M_{yd}^2 + M_{zd}^2)}$
Suction Loading (US Customary) = $F_{rs} + M_{rs}/3$
Discharge Loading (US Customary) = $F_{rd} + M_{rd}/3$
Suction Loading (Metric) = $F_{rs} + M_{rs} \cdot 1.09$
Discharge Loading (Metric) = $F_{rd} + M_{rd} \cdot 1.09$

**FIGURE 36 – Load Translation Formula**

Where:

Forces are expressed lbf or N and moments are expressed in lbf•ft or N•m.

Forces and Moments are positive in the directions shown on Figure 50.

$F_x$  = Calculated total force in the x direction at the center of the pump.

$F_{xs}$  = Force in the x direction applied to the suction nozzle.

$F_{xd}$  = Force in the x direction applied to the discharge nozzle.

$M_x$  = Calculated total moment about the x-axis at the center of the pump.

$M_{xs}$  = Moment about the x-axis applied to the suction nozzle.

$F_{rs}$  = Resultant force applied to the suction.

$M_{rs}$  = Resultant moment applied to the suction.

$H$  = Vertical distance from the centerline of the pump to the top of the discharge flange.

$L$  = Horizontal distance from the centerline of the discharge to the front of the suction flange.

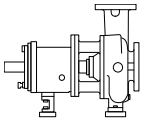

Pump Size	US Customary (Inches)			Metric (Meters)		
	H	L	M	H	L	M
1 x 1.5-6	6.5	4	0	0.165	0.102	0
1.5 x 3-6	6.5	4	0	0.165	0.102	0
2 x 3-6	6.5	4	0	0.165	0.102	0
1 x 1.5-8	6.5	4	0	0.165	0.102	0
1.5 x 3-8	6.5	4	0	0.165	0.102	0
2 x 3-8	9.5	4	0	0.241	0.102	0
3 x 4-8	11	4	0	0.279	0.102	0
3 x 4-8G	11	4	0	0.279	0.102	0
1 x 2-10	8.5	4	0	0.216	0.102	0
1.5 x 3-10	8.5	4	0	0.216	0.102	0
2 x 3-10	9.5	4	0	0.241	0.102	0
3 x 4-10	11	4	0	0.279	0.102	0
4 x 6-10G	13.5	4	0	0.343	0.102	0
4 x 6-10H	13.5	4	0	0.343	0.102	0
1.5 x 3-13	10.5	4	0	0.267	0.102	0
2 x 3-13	10.5	4	0	0.267	0.102	0
3 x 4-13	11.5	4	0	0.292	0.102	0
4 x 6-13	12.5	4	0	0.318	0.102	0
6 x 8-13	13.5	4	0	0.343	0.102	0
8 x 10-13	16	6	0	0.406	0.152	0
4 x 6-16	18	6	0	0.457	0.152	0
6 x 8-15	18	6	0	0.457	0.152	0
8 x 10-15	19	6	0	0.483	0.152	0
8 x 10-15G	19	6	0	0.483	0.152	0

FIGURE 37 – Dimensions

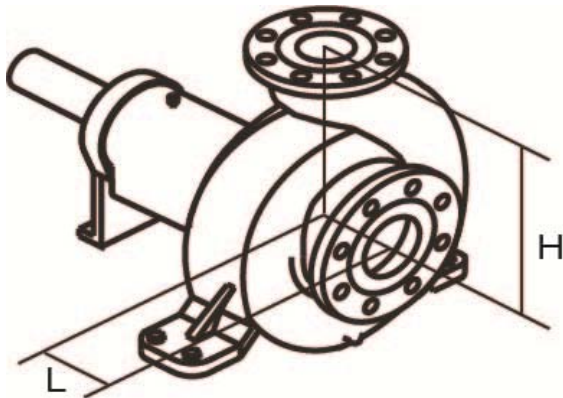

FIGURE 38 – OSG Dimensions